

Ersa Rework & Inspection Systems

We take care of excellent worldwide joints

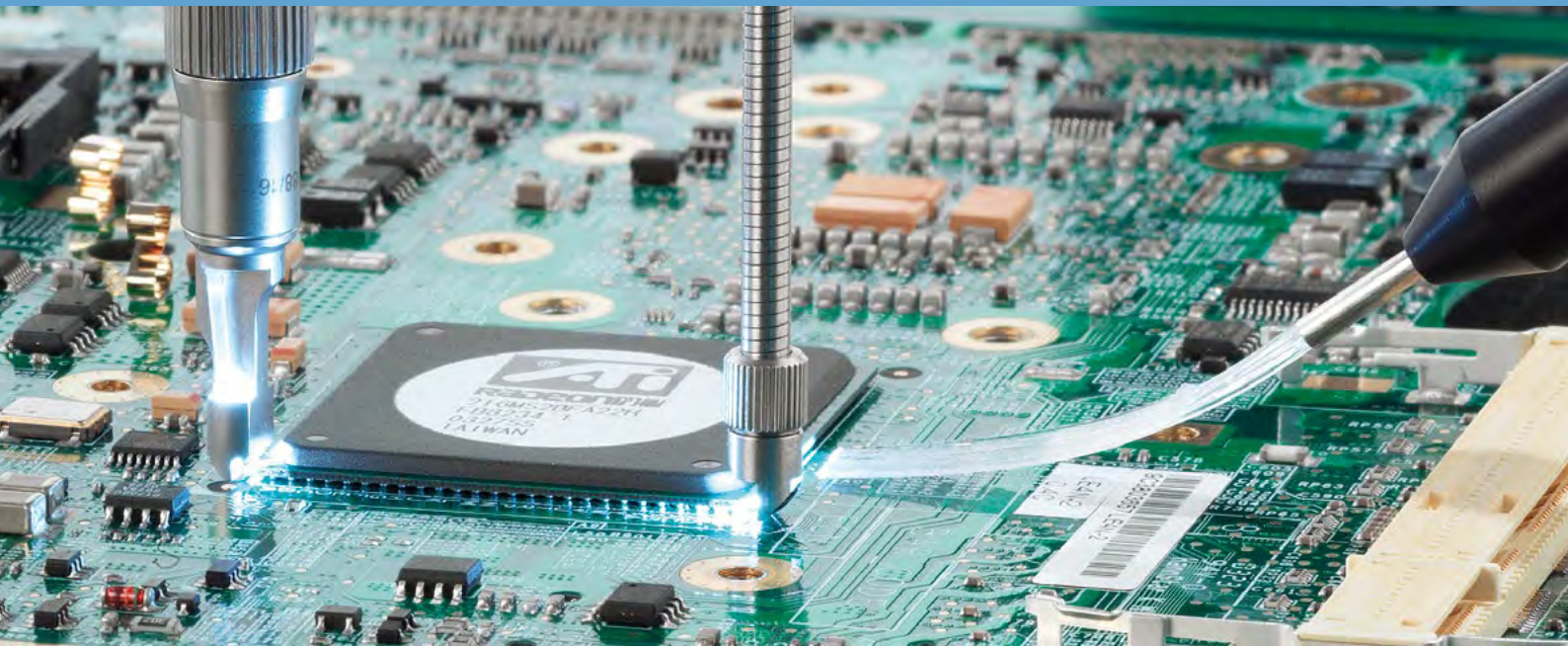

Content

Ersa Rework Systems

HR 550	4 - 5
HRSOFT 2	6
HR 600/2	7 - 8
HRSOFT	9
HR 600 XL	10
HRSOFT 2	11
IR/PL 650	12 - 14
RPC 650	15
IR/PL 650 XL	16 - 17
IR 550	18
IRSOFT	19
HR 200	20
HR 100 and IRHP 100	21
RPC 500	22
DIP&PRINT STATION	23
Accessories	
Placement nozzles and suction cups	26
Temperature sensors	27
Additional equipment	27
Consumable items	28
Soldering tips	28
PCB tables, holders and more	29
Baffles HR 600	30
DIP&PRINT STATION	30

Ersa Inspection Systems

ERSASCOPE 2	36 - 39
ERSASCOPE 1	40 - 41
MOBILE SCOPE	42 - 43
ImageDoc	44 - 46
System configurations and options	
ERSASCOPE 2	48
ERSASCOPE 1	49
MOBILE SCOPE	50



Ersa Rework and Inspection Systems

Award-winning and a class of its own!

Over the past two decades, rework and repair of electronic assemblies has been one of the most exciting and challenging undertakings in the industry. The increasing complexity of the PCBs, as well as the advancements in packages has put additional demands on both rework specialists and their equipment. Applications-oriented, innovative solutions are the key to success in this demanding field.

Ersa took on the rework challenge almost twenty years ago as it introduced its first patented medium wavelength infrared rework system, the Ersa IR 500. Today, we are proud to boast one of the world's largest installed equipment bases of over 6,000 systems ranging from smaller bench top units to larger semi-automated machines.

Ersa rework systems have proven themselves to be the undisputed leaders in handling the largest variety of rework applications.

From the smallest 0201 up to the largest SMT connector (120 mm), from SMT Flip-Chips to THT Pin Grid Arrays, from BGA on flex circuit to stacked BGAs and from metal shields to plastic processor sockets, the safe IR technology handles it all.

Now recognized as one of the market leaders in the rework field, Ersa is happy to present its most complete range of products in this catalog.

For nearly twenty years now, thousands of users worldwide have been benefiting from the ability to inspect hidden solder joints with the patented and award-winning ERSASCOPE inspection technology.

Industry experts recognize the critical importance of using ERSASCOPE technology for the inspection of hidden solder joints. In combination with X-ray inspection equipment, the ERSASCOPE provides the most complete view of potential problems.

ERSASCOPE remains to be the undisputed industry standard for optically inspecting BGAs and other hidden solder joints!

Whether for inspection under Flip-Chips or for inspection where other microscopes cannot see, ERSASCOPE technology offers a significant added value to any quality assurance program.

Our Portfolio

- Stencil printers
- Reflow systems
- Selective soldering systems
- Wave soldering systems
- Rework systems
- Inspection systems
- Soldering stations
- Solder fume extraction units
- Solders, fluxes and more
- Staff training and certification



Ersa HR 550 Hybrid Rework System

Guided rework!



Reflow process camera on the HR 550

High-performance rework for professionals!

The Ersa HR 550 hybrid rework system addresses all users with highest requirements in terms of precision and process safety in electronic assembly rework applications.

The HR 550 features a 1,500 W high-performance hybrid heating element to desolder and solder SMT assemblies up to dimensions of 70 x 70 mm. The 2,400 W infrared bottom heater with three zones guarantees homogenous heating of the complete assembly. Contact-free and direct-contact temperature sensing

directly at the component and optimized process control guarantee ideal soldering and desoldering. The removal and placement of the assemblies ensues by means of a high-

precision vacuum pipette which is integrated into the heating head. Both the exchangeable heating head and the vacuum pipette are each activated by stepper motors. An inte-

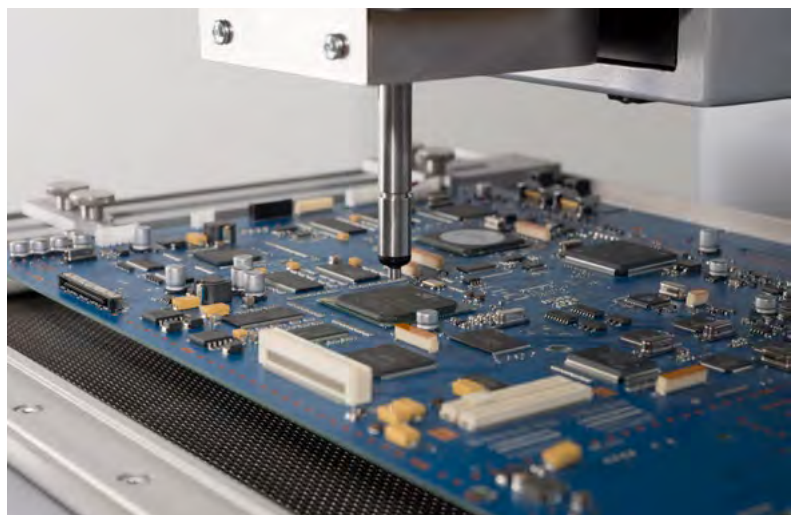

Ordering information:

Order number	Description
0HR550	Ersa HR 550 Hybrid Rework System
0HR510	RPC camera HR 550
OPR100	Ersa DIP&PRINT STATION , complete

Ersa HR 550

Reworking at the highest level

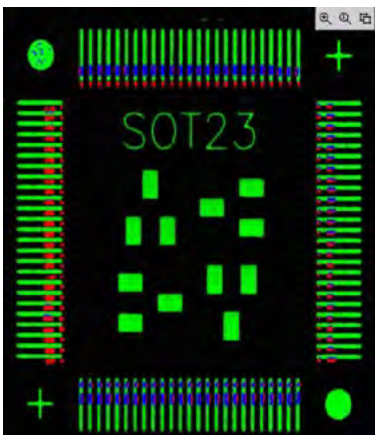

Computer-supported alignment of a QFP

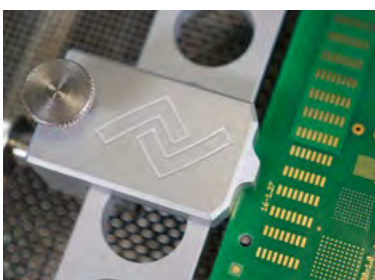

Flexible circuit board holder

grated force sensor recognises contact between component and printed circuit board. A particularly beneficial feature for the user is the practical arrangement of the control elements and the computer-controlled alignment of components based on brilliant, high-definition camera images. The HR 550 is fitted for use with the Ersa DIP&PRINT STATION. The operation of the system ensues via the newly-developed operating software and ergonomically-arranged control elements on the equipment.

Features of the HR 550

- High-definition camera for placement and process tracking
- Computer-supported component alignment, digital split-optic
- 1,500 W high-performance hybrid heating with medium wave infrared heater and additional convection heating with top heater
- Full-surface 2,400 W medium wave infrared bottom heating
- Motorized heating head with vacuum pipette
- Ergonomically optimized system operation
- PCB dimensions of up to 382 x 270 (+x) mm
- Component handling of sizes from 0.5 x 0.5 mm up to 70 x 70 mm
- Working depth of up to 349 mm
- Operating distance of between 30 and 60 mm from the top heater and 35 mm from the bottom heater
- Field of view placement camera with 70 x 70 mm (wide-angle) and 25 x 33 mm (telephoto)
- Operation via HRSoft 2
- Compact dimensions (B x T x H) – 573 x 765 x 545/747 mm (heating head below/above)

HRSOft 2

Transparent user guidance in rework

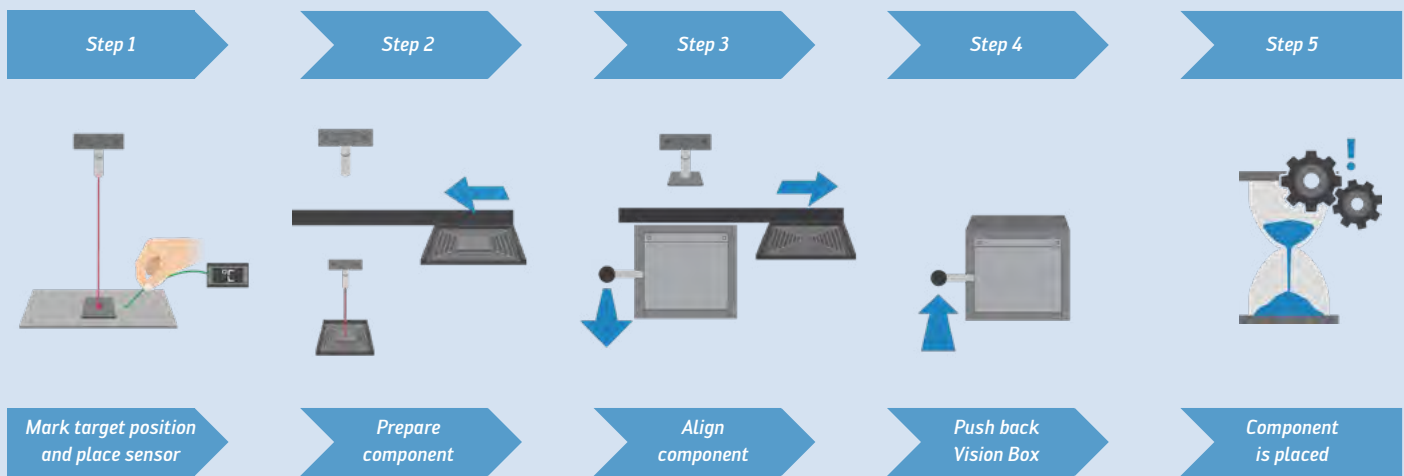

HRSOft 2 – User guidance via pictograms showing component placement as example



*HRSOft 2 –
Enhanced
Visual Assistant*

Under the motto **Enhanced Visual Assistant** (EVA), the HRSOft 2 user surface offers every assistance for completing rework tasks quickly and reliably.

Even the novice user quickly becomes adept thanks to the well-structured and clearly laid out software. Predefined soldering and desoldering profiles are simple to select and the user is guided through all the rework process steps. Easy-to-understand pictograms and instruction texts provide direction for the user.

In the computer-aided placement of components, HRSOft 2, the new Ersarework software, provides the user with brilliant, high-definition images of circuit boards and component leads. In this way, all SMD models can be aligned very quickly and with minimum fatigue for the user.

Together with a database supported archive and further useful functions, special aids such as a digital split optic for aligning large QFPs round off the features of HRSOft 2.

Ersa HR 600/2 Hybrid Rework System

Flexible, efficient, automated, reliable!



IMAGESOFT Target

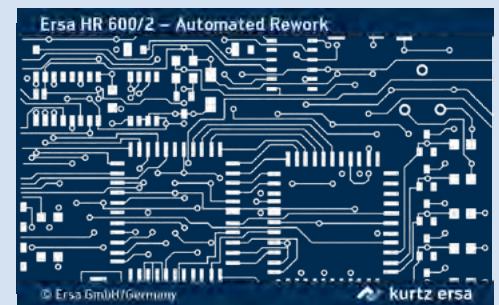

Ersa high-end rework

The task formulated for the Ersa HR 600/2 hybrid rework system was to offer professional, automated rework of sub-assemblies for the electronic industry. With the system now at hand, almost all high pin-out components that may be found on modern board assemblies, and of virtually any shape, can be reliably reworked. The core competencies of this universal rework system are the placement of components, their lifting off and their controlled setting down, as well as the soldering process.

Special attention was given to the automation of the individual process steps. All operations can be controlled in a step-by-step mode by the operator himself, or they can be combined into an automated operation, requiring very few interventions by the operator.

To preheat the complete board area of the assembly mounted in the PCB holder, the system utilizes highly dynamic IR heating elements in the bottom heater. A hybrid heating head combines the heat transfer method of IR radiation with that of convection heating for a targeted and therefore highly efficient warming of the components to be worked on. Applying this method, quick and top-quality desoldering and soldering results are being achieved. An optional Reflow Process Camera (RPC) with LED illumination is available for process monitoring and documentation.

Component placement is a largely automatic process; integrated image processing software assesses data supplied by the two installed cameras. The component position is calculated and placed using a vacuum pipette mounted on an axis system.

The system is prepared for the Ersa Dip&Print Frame. Paste printing takes place off-side on the Dip&Print Station; fluxing the component is equally a fully automated process.

Stainless steel adapters can be inserted in the hybrid heating head as an option, in order to further limit the area to be heated on the board. Available baffle dimensions are 40 x 40 mm, 30 x 30 mm, 20 x 20 mm.

In conjunction with the two separately controllable zones the operator obtains thus various options for a safe top-side heating of assemblies.

Ersa HR 600/2

Rework of board assemblies newly defined



Ersa HR 600/2 VOIDLESS

Features of the HR 600/2 and RPC

- High-performance hybrid heating head with 2 heating zones (800 W)
- Three programmable lower IR heating zones (2,400 W)
- Temperature acquisition by 3 channels – 1 IRS sensor, 2 AccuTC thermocouples (K-type)
- Board size up to 300 (+x) x 390 mm
- Board size up to 300 x 535 mm (option)
- Motorized heating head with vacuum pipette
- Interchangeable adapters
- Cooling with hybrid head and compressed air-knife from below
- Laser pointer for component ID and board location
- Precision axis system with stepper motors
- 2 high-quality USB 2.0 cameras and image processing
- Adaptive LED illumination
- Handling of component sizes from 1 x 1 mm up to 50 x 50 mm
- Positional accuracy up to +/- 0.025 mm
- PC interface via USB port
- Operation via HRSoft
- High-resolution USB 2.0 camera for process monitoring (option)
- Dimmable LED point light source for RPC
- Multiple adjustment of RPC holder



RPC Reflow Process Camera



Hybrid heating head with interchangeable adapters

Ordering information:

Order number	Description
0HR600/2	Ersa HR 600/2 hybrid rework system
0HR610	Ersa Reflow Process Camera for HR 600/2, complete
0PR100	Ersa Dip&Print Station , complete
0HR-VL1	Ersa VOIDLESS module for HR 600/2, complete

HRSOft

The combination of proven technology and innovative image processing sets new standards!

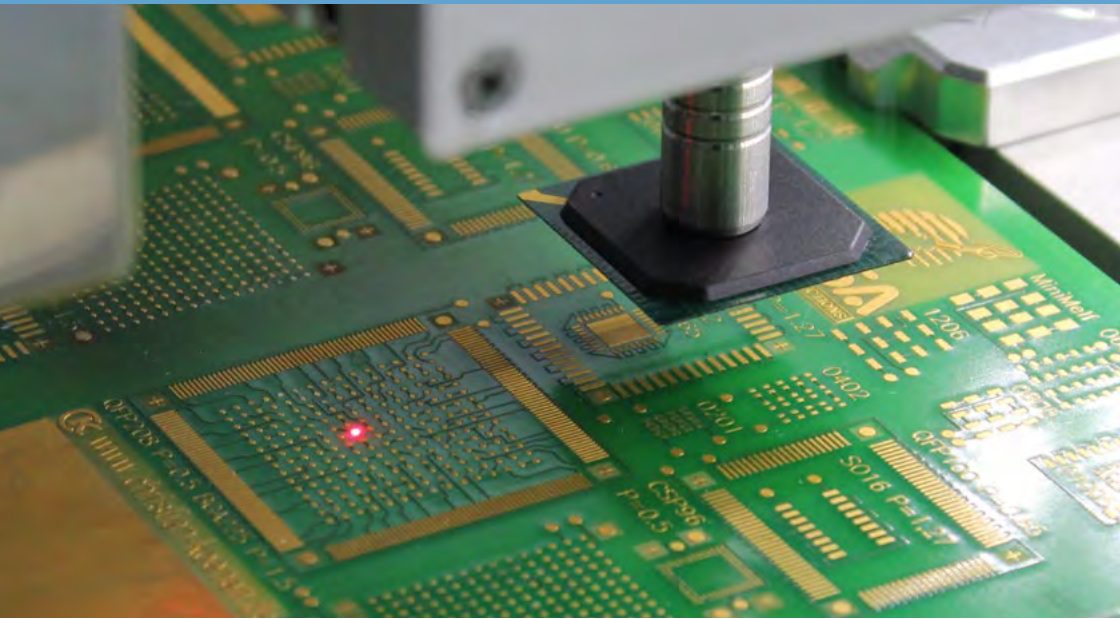

By continuing the development of the universal control software platform of IRSoft, a new control software has been created for the HR 600 called HRSOft. All of the process steps of the HR 600/2 are supported by this user-friendly software.

Through HRSOft, the user can manually control all functions of the system with a simple mouse click. During a rework process the user can select to operate the HR 600/2 in either a step-by-step or an automatic mode.

The library feature of HRSOft clearly displays the stored soldering and desoldering temperature profiles. A soldering or desoldering process can be started either manually or automatically, whereas the results are automatically recorded regardless of the starting method.

For placing the new component, the step-by-step mode or the automatic process mode are again available. At all times the individual functions of the system, axes and cameras can be manually controlled.

The integration of an optional USB reflow process camera (RPC) for the HR 600/2 is also provided for. This camera with a wide-aperture lens and a LED point light source visualizes the solder process in real time. In addition to the automated operation of the HR 600/2, HRSOft offers an archive in which all rework process records are administered and stored.

And finally, every HR 600/2 can be expanded to a rework system with the retrofitable VOIDLESS module, which minimizes the occurrence of voids (entrapped gas) in solder joints of critical applications!



Image of the target position

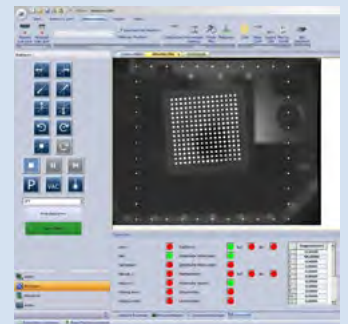

Determining the component connections



Superimposing of component and target position

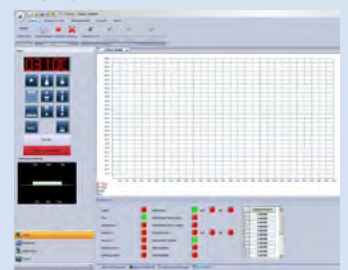

HRSOft process recording

HR 600 XL

Professional repair of big boards!

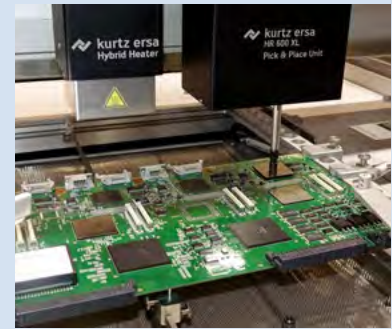
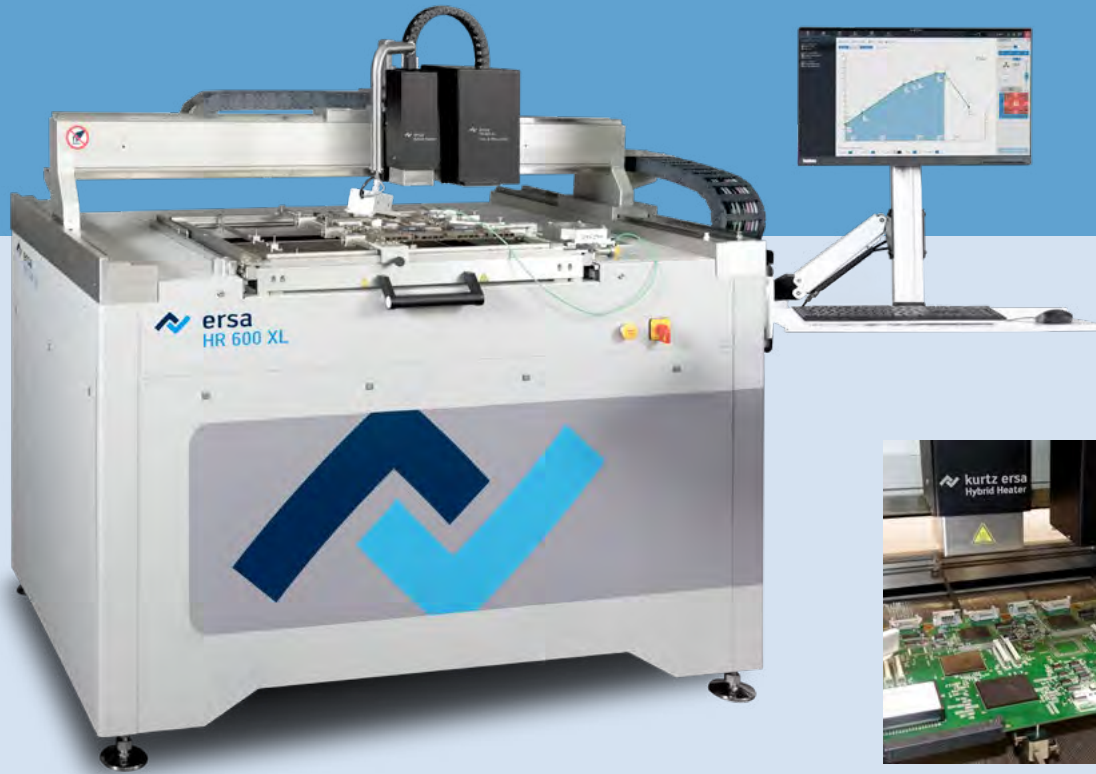

Automatic processing of big assemblies

The Ersa HR 600 XL was designed for the professional repair of BTC (bottom-terminated components) on big boards. With an active heating area of 625 x 625 mm (24 x 24 in) and its capability to process PCBs with a thickness of up to 10 mm, the system opens up rework applications in telecommunications, network technology and IT-infrastructure.

The bottom-side IR Matrix Heater™ with 15 W power consists of 25 individually controllable heating elements. In this way, the ideal heat distribution can be set for each application. The

highly efficient 800 W hybrid heating head executes the desoldering or installation of components such as BGAs of up to 60 x 60 mm (2.36 x 2.36 in) to chip components with the usual high Ersa quality.

By means of image processing, the system performs a precise automatic component alignment and places components with an accuracy of ± 0.025 mm thanks to its exact axis system. The HR 600 XL can be operated in fully automatic or semi-automatic mode and thus provides highest flexibility for the users.

Furthermore, the HR 600 XL is ready for use with the Ersa DIP&PRINT STATION, to prepare components with defined amounts of flux and solder paste. For visual process control, an optional high-resolution reflow process camera is available. Process

control and documentation is realized with the HRSOft 2 software package.

Features of the HR 600 XL

- Highly efficient 800 W hybrid heating head
- Large-area IR Matrix bottom heater with 25 single heating elements (600 W each)
- Process observation with up to 8 thermocouples
- Automatic and precise component alignment with the help of machine vision
- Highly accurate, motor-driven axis system for component placement (± 0.025 mm)
- User independent, reproducible repair results guaranteed
- Process control and documentation via the operator software HRSOft 2
- Fully automatic or semiautomatic operation
- Suitable for the use of the DIP&PRINT STATION

Ordering information:

Order number	Description
OHR600XL	ERSA HR 600 XL hybrid rework system
OHR610XL	Reflow process camera for HR 600 XL
OPR100	DIP&PRINT STATION , complete

HRSoft 2

The modern operating platform for Ersa rework systems (also see page 6)

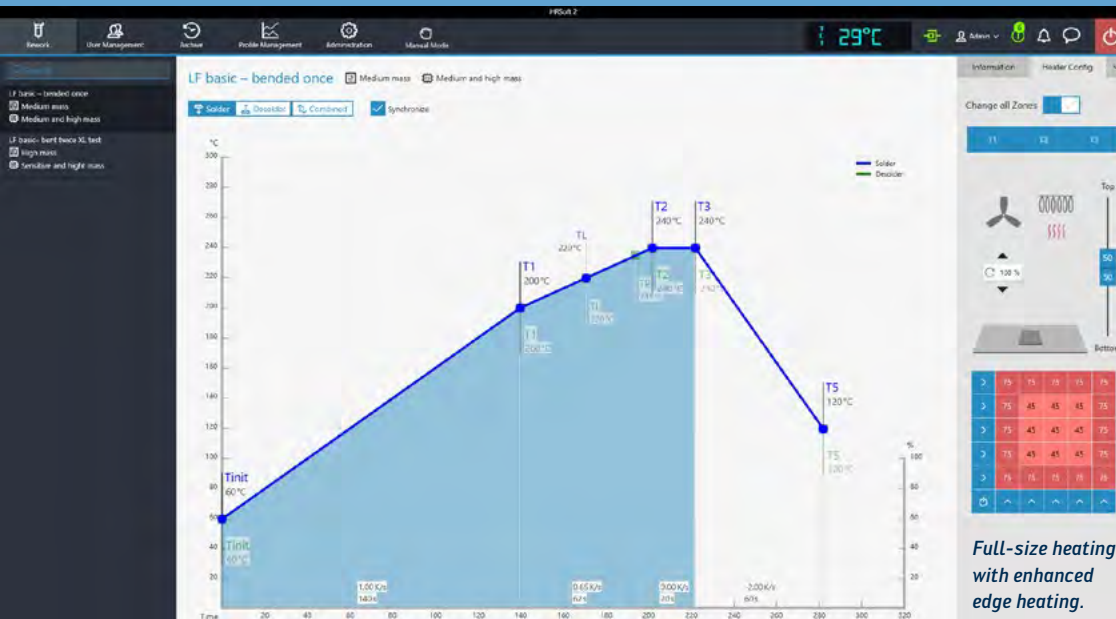

The user interface of HRSoft 2 sets new standards in rework, both technologically and optically. Being a clearly structured software platform for current and future systems, it offers the user all functions of the respective system and guides him through the single steps of the rework process.

Innovative image processing and powerful database management for profile and process parameters as well as the modern handling are just some of the features of this software package.

The use of different Ersa rework systems is also simplified by the fact that the same functions are represented in the same way. There is no need for a time-consuming adaptation.

Currently, the HR 550 and the HR 600 XL are operated by HRSoft 2. It is also the communication interface for connections to Manufacturing Execution Systems (MES).

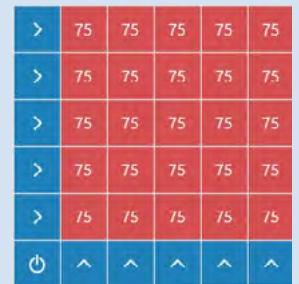

Full-size heating with homogeneous power in all zones.



Full-size heating with edge enhancement and "hot spot".



Full-size heating with edge enhancement and "cold spot".



Segmented heating with homogeneous power in all zones.

Ersa IR/PL 650

The Ersa rework power-pack for demanding applications

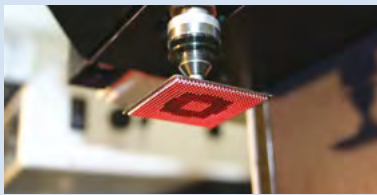

"Auto Pick & Place" allows for rapid, precise and repeatable results!



Real-time rework process visualization of BGA during reflow



The IR/PL 650 provides a very high heating power (4,400 W) for large and complex PCBs. Offering a high degree of automation, the IR/PL 650 requires only little user intervention. This guarantees stable and repeatable rework processes for all applications.

The IR rework system is made up of four distinct operational modules:

- 1. IR 650 selective reflow module***
- 2. RPC 650 camera module***
- 3. PL 650 placement module***
- 4. IRSoft software module***

Recommended accessories:

It is recommended to purchase: Split Optic Kit for placing large PQFPs, Component Centering Station for alignment of Fine-Pitch components and the Rework Starter Kit. Special desoldering tools, such as the CHIP TOOL to remove smallest SMDs and the X-TOOL for TH desoldering can be used with the soldering station integrated into this system. For ordering details, please refer to the Ersa tools catalog or visit www.ersa.com. A complete listing of all rework accessories is available on pages 26 to 30.



Ersa IR 650

Selective BGA/SMT reflow technology for rework

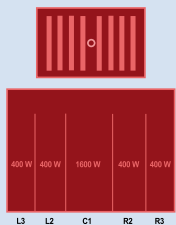

The 4,400 W DynamicIR system has 4 top and 5 bottom-side heating zones

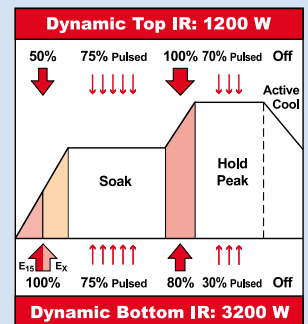
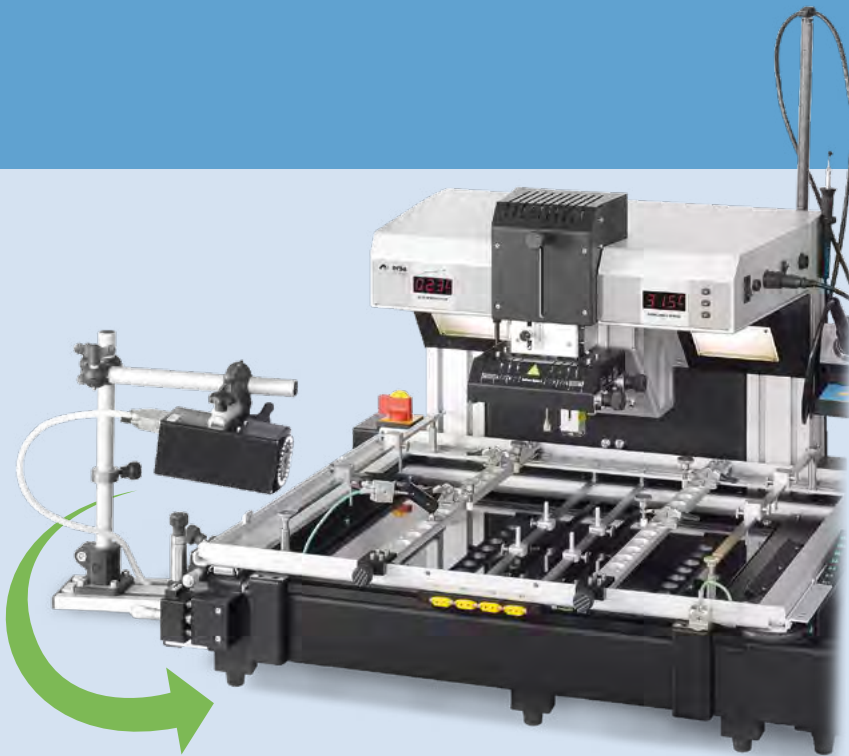

The IR 650 selective reflow module uses DynamicIR heating technology for fully automatic dynamic control of the top (1,200 W / 60 mm x 120 mm) and bottom (3,200 W / 350 mm x 450 mm) IR heaters. The total available power (4,400 W) to the selective reflow system is spread across 4 separately controllable heating zones on the top and 5 zones on the bottom. Depending on board size, the thermal mass of the substrate and

component size, the DynamicIR technology guarantees that the required heat energy is delivered at the precise time and location in order to ensure that the component and board exactly follow the prescribed temperature profile.

Now combined with the enhanced capability to run an extended or flat peak, this revolutionary technology affords the lowest temperature deltas across the component, the highest degree of process safety and greatly reduces PCB warpage.

Ordering information:

Order number	Description
0IR650A	IR 650 IR rework system with RPC 650 module incl. IRSoft, 2 pcs. AccuTC, 1 pc. Flexpoint TC holder, integrated cooling fans and soldering station

Features of the IR 650 module

- Four programmable heating zones, top (1.200 W)
- Five programmable heating zones, bottom (3.200 W)
- PCB size up to 460 x 560 mm
- 5-channel temperature recording: 1 IRS sensor, 4 AccuTC thermocouples (K-type)
- DynamicIR and Multi True Closed-Loop controlled heating technology with APR process repetition
- Laser pointer for component ID and PCB positioning
- Motorized reflow head with vacuum pipette
- Removable PCB fixing frame with top- and bottom-side center supports
- Integrated axial top cooling fans and laminar bottom cooling fans
- Vacuum pipette for component handling
- Integrated digital soldering station with soldering iron
- PC-ready via USB
- Operation via IRSoft

Ersa PL 650

Precision component placement

*"Auto Pick & Place"
allows for rapid,
precise and
repeatable results!*

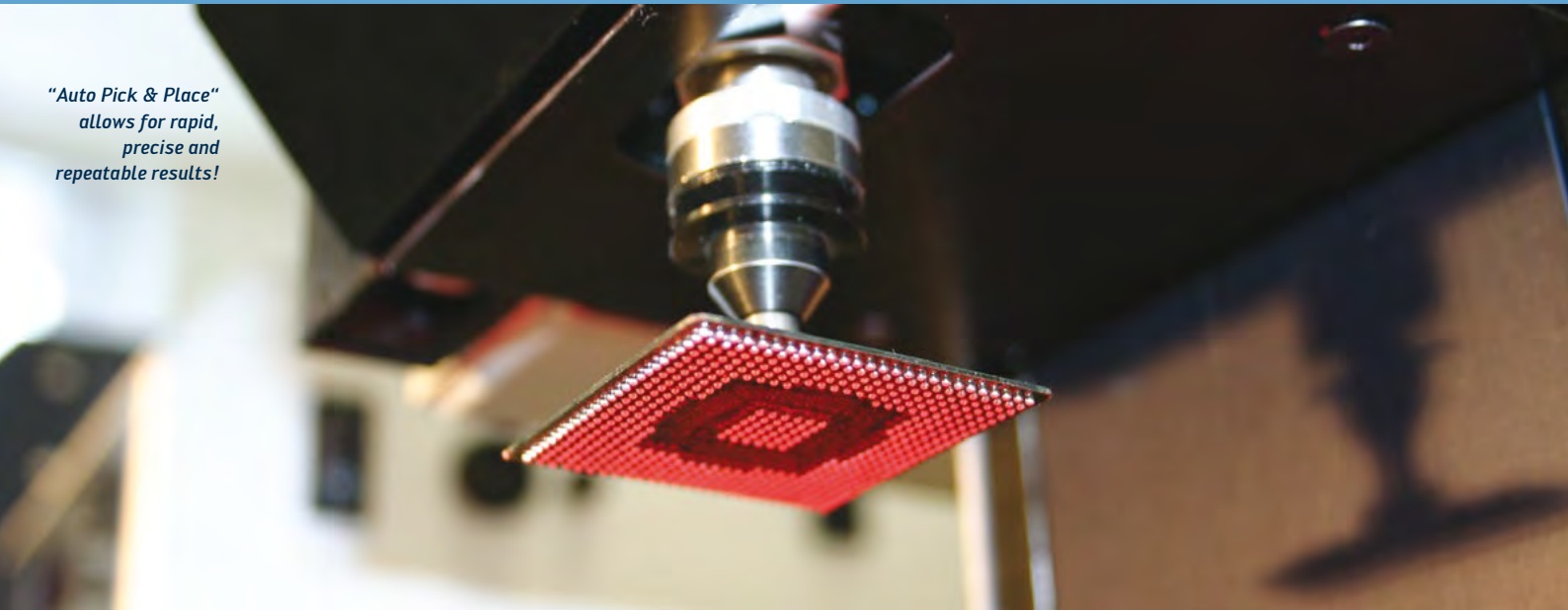

The PL 650 module is the second generation precision placement system designed for the largest range of components. It provides increased automation and excellent repeatability. A highly sophisticated and fully automated, pressure triggered component placement head drops off the component at the same contact pressure (1.5 N) as an in-line pick & place machine.

A high-resolution camera with motorized zoom permits highly precise alignment of component leads to lands with up to 300x enlargement. The excellent image quality is supported by a high-contrast, separately controlled two-color LED lighting system from four sides. The Auto Pick & Place mode guarantees repeatable and precise results.

Features of the PL 650 module

- CCD camera with 25x optical and 12x digital zoom
- Motorized placement head, camera zoom and focus
- Pressure triggered head with automatic drop-off
- "Auto Pick" & "Auto Place" with +/- 0.010 mm accuracy
- Component handling from 1 x 1 mm to 60 x 60 mm
- 60 x 60 mm split optic cassette for large QFPs and BGAs (option)
- Four-side red/white LED illumination
- One push auto focus and white balance
- Programmable camera presets
- Remote control via PC using IRSofT

Ordering information:

Order number	Description
OPL650A	PL 650 motorized precision placement system (PL 650 module attachable to IR 650 and controlled via IRSofT)

Ersa RPC 650 Reflow Process Camera



Live video
pop-up window
during profile
recording

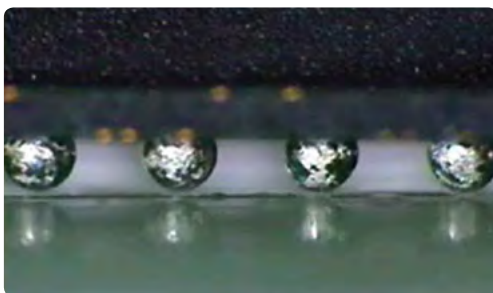
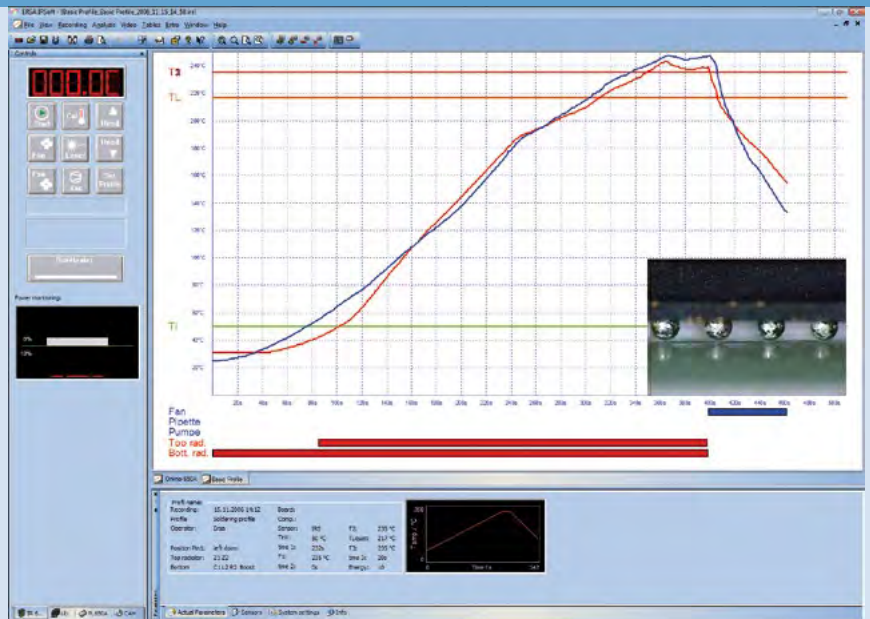

Real-time rework process visualization of BGA during reflow



RPC camera with LED ring light

The RPC 650 module is attached to the IR 650 module and uses a high-power (up to 300x enlargement) motorzoom camera, a controllable LED ring lighting system, and a robust movable swivel arm in order to visualize the rework process in real time.

The reflow process can be watched from various angles and with high magnification on even the smallest of components.

Through the real-time observation of the soldering and desoldering process, the user can capture the melting point of the solder and directly calibrate the unit. This feature substantially improves process reliability.

Features of the RPC 650 module

- CCD camera with 25x optical and 12x digital zoom
- Motorized zoom and focus
- LED ring light, one push auto focus and white balance
- Programmable camera presets
- Movable and fixable swivel camera arm
- Remote control via mouse or PC using IRSoft

Ersa IR/PL 650 XL

The flexible rework power-pack for the handling of extra large PCBs

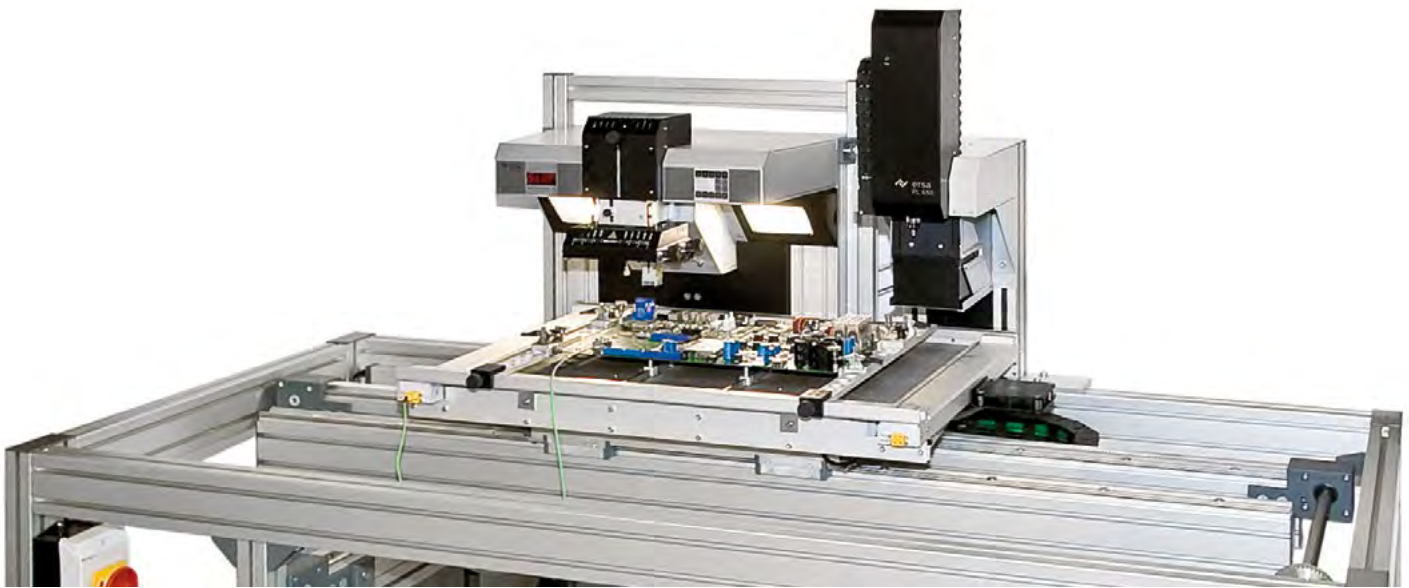

1 5	2 5	3 5	4 5	5 5
6 2	7 2	8 1	9 3	10 3
11 2	12 2	13 1	14 3	15 3
16 4	17 4	18 4	19 4	20 4

1 - 20 = heating element number
1 - 5 = zones

For today's rework operators working on large PCBs one truth remains constant – the rework difficulty increases with the size of the PCB. From a profitability standpoint, reworking large PCBs represents a tremendous risk, due to the very high PCB price. One failed rework procedure could destroy a PCB, thereby losing the high material costs and follow-on profits!

PCBs of up to 20" x 24" or 500 mm x 650 mm can now be safely and rapidly reworked using one of the industry's largest and most powerful bottom-side heaters – an 8,000 W medium wavelength IR heater measuring 500 mm x 625 mm. Total system power is 9,200 W.

These extra powerful bottom and top heaters are necessary for large boards, especially for those which are thicker than 3 mm. Unless the entire

board area is efficiently preheated from the bottom, such boards show the tendency of bending and warping during the rework procedure. Divided into 5 separately controllable bottom-side heating zones and 4 top-side zones, the operator on the IR/PL 650 XL can individually set the heating power to each zone in order to find the optimal preheating conditions.

In addition to the total size and power of the bottom heater, an important factor is the position of the PCB over the bottom heater. The IR/PL 650 XL has a completely redesigned PCB holder table which exposes the entire PCB to the heater area. No matter where the component to be repaired is located on the board, the entire PCB is preheated. No cold spots means less warping.

Ersa IR/PL 650 XL



The large PCB table design guarantees that all shapes of boards are carried in an optimal manner. Top- and bottom-side support rails are easy to insert and adjustable to the actual rework task within minutes. The table includes a 45° butterfly mechanism to lift the entire PCB while it is inserted in the holder and thus provides easy access to the bottom side. The operator can easily attach thermo probes on the bottom side, position support pins or carry out other “down under” operations like shielding heat sensitive components.

Finally, the IR/PL 650 XL has taken a completely new approach to cooling, as large PCBs require a higher cooling volume. Similar to Ersa’s wave soldering machines, this rework system has a new and highly efficient compressed air cooling system.

Using an air tube which extends the entire length of the bottom-side heater, laminar flow cooling takes place via very fine air outlets. The air flow rate can be adjusted for a faster or slower cooling gradient.

Features of the IR/PL 650 XL

- Four programmable IR heating zones, top (1,200 W, 120 x 60 mm)
- Five programmable IR heating zones, bottom (8,000 W, 500 x 625 mm)
- PCB size up to 500 x 650 mm
- 5-channel temperature recording: 1 IRS sensor, 4 AccuTC thermocouples (K-type)
- DynamicIR and Multi True Closed-Loop controlled selective reflow process with APR
- Laser pointer for component ID and PCB positioning
- Motorized reflow head with vacuum pipette
- Tiltable PCB fixing frame with top- and bottom-side center supports
- Integrated axial top- and laminar bottom cooling fans
- Vacuum pipette for component handling
- PC ready via USB
- Operation via IRSoft

Ordering information:

Order number	Description
0IRPL650A-XL	IR/PL 650 XL semiautomatic IR rework system incl. RPC camera

Ersa IR 550

Unbeatable in price and performance!

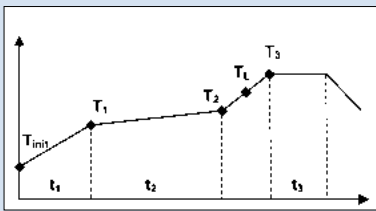

The IR 550 provides high profile flexibility with a flat peak

Features of the IR 550

- High-performance IR heater, top (800 W)
- One programmable IR heating zone, bottom (800 W)
- 2-channel temperature recording: 1 IRS sensor, 1 AccuTC thermocouple (K-type)
- PCB size up to 250 x 320 mm
- DynamicIR and closed-loop selective reflow process
- Laser pointer for component ID and PCB positioning
- Reflow head with vacuum pipette
- Integrated axial top cooling fan
- Integrated digital soldering station with soldering iron
- PC-ready via USB
- Remote control via keypad or IRSoft

The IR 550 is the best seller in the Ersa rework line with thousands of systems sold. This module uses the DynamicIR heating technology for fully automatic dynamic control of the top (800 W / 60 mm x 60 mm) and bottom (800 W / 135 mm x 260 mm) IR heaters.

Depending on board size, thermal mass of the substrate, and component size, the DynamicIR heaters (total of 1,600 W) guarantee that the required heat energy is delivered at the precise time and location in order to ensure that the component exactly follows the prescribed temperature profile.

Combined with the enhanced capability to run a flat peak, this revolutionary technology affords the lowest temperature deltas across the component, and greatly reduces PCB warpage.



SMT Vision Award:
Best New Rework
Product

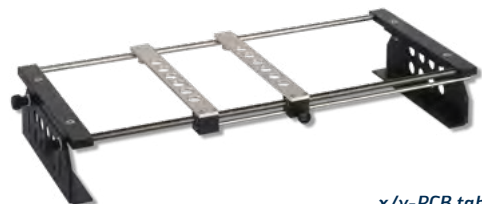

x/y-PCB table
for IR 550

Ordering information:

Order number	Description
0IR550A	IR 550 rework system (w/o x/y-PCB table) incl. IRSoft, 1 x AccuTC and soldering station
0IR5500-01	x/y-PCB table (not required with PL 550)

Ersa IRSoft

User-friendly system control and process documentation for Ersa rework systems

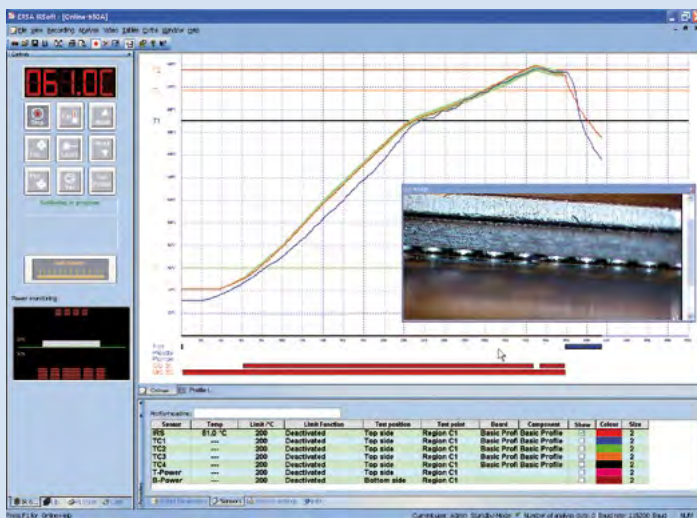

Live temperature recording with real-time video process window

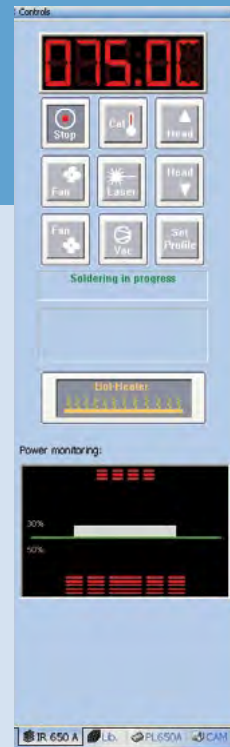

IR 650, IR/PL 650 XL



Customized library

Ersa has rounded off its rework product platform from the handheld HR 100 all the way up to the IR/PL 650. IRSoft is a universal system control, process documentation and process visualization software platform designed for use with all Ersa rework systems, from the smallest to the largest. In this manner, Ersa ensures operators an easy move between systems with hardly any learning curve required.

Today, with 20 years of rework experience and over 6,000 systems installed, we have continually added features and functions which were demanded by the market and have provided free updates to the existing user base.

This universal software concept ensures that operators can easily operate the different Ersa systems without additional training requirements.

Features of the Ersa IRSoft

- Control software for IR/PL 650 & XL, IR/PL 550 and HR 100 (with IRHP 100)
- User-friendly interface with online help
- Visualization of all rework process data with up to 5-channel temperature recording
- Live process video window for RPC 650, RPC 550 and RPC 500
- Customized user admin rights and library for soldering and desoldering profiles
- Complete process documentation and analysis
- Operating systems – Windows 7, 8 and 10
- All systems communicate over a fast USB 2.0 port



Rework process visualization with live image window

Ersa HR 200 Hybrid Rework System

Rework out of the box!

As easy as one, two, three.



Easy parameter setup					
		Top Heat		Parameters	
		smooth	intensive		
	time*	180 s	180-120 s	120-90 s	90-60 s
	power level	1	2	3	4
Bottom Heat	smooth	1	ultra light weight	sensitive bottom side	
	intensive	2	sensitive top side	typical SMT application	intensive top
		3			
		4	intensive bottom		heavy duty caution

* Expectable soldering time, depending on application an preheating with bottom heater.



Useful hybrid adapter set

Unpack, setup, solder! It's simple as that to rework a PCB nowadays. The Ersa HR 200 hybrid rework system contains a 400 W high-power hybrid heating element to desolder and solder SMT components of up to 30 x 30 mm. In addition, the system can operate a powerful 800 W infrared heating plate. This bottom heater guarantees ideal preheating of the assembly to rework. The operator selects the required power for top and bottom heating with a control knob, each with four levels. A foot switch activates the heating process. The operator's hands are free to remove the desoldered component with appropriate tools.

Depending on the assembly and the preselected power a typical soldering time for components can range from 60 to 180 s (1 -3 min). During working breaks, the bottom heater switches back to standby level. The integrated PCB holder locates the assembly in optimum working distance to top and bottom heater.

Ersa recommends an optional cooling fan, a thermocouple and a temperature-measuring instrument to complete the workplace. Additional accessories including a Reflow Process Camera to observe the soldering processes rounds off the equipment.

Technical highlights:

- 400 W Hybrid high-power heating element
- Optional 800 W IR-heating plate
- Simple power selection in four levels
- Foot switch to activate the heating process
- Very compact and handy system (footprint 300 x 300 mm)

Order information:

Order No.	Description
OHR200	Ersa HR 200 Hybrid Rework System
OHR200-HP	Ersa HR 200 Hybrid Rework System with heating plate
OHR200-16	Hybrid adapter set Ersa HR 200

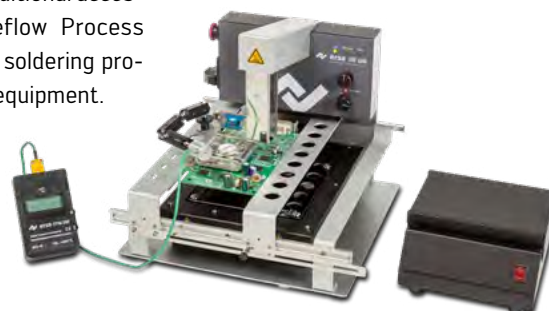

HR 200 with cooling fan and temperature measuring device - the right power level for each application

Ersa HR 100 and IRHP 100

Combined handheld and benchtop rework system



Features of the HR 100 and IRHP 100

- HYBRID TOOL with 200 W heating element
- Positioning laser and LED display in the HYBRID TOOL handle
- Three exchangeable hybrid adapters
- Low-noise rework blower (below 40 db)
- Integrated vacuum pump and VAC-PEN
- 2-channel temperature recording: 1 AccuTC thermocouple (K-type), 1 IRS sensor
- PC-ready via USB
- HYBRID TOOL holder with height adjustment
- 800 W high-performance IR heating plate with glass cover
- Board holder (250 x 290 mm)
- Control via rotary push button and IRSoft

The HR 100 uses Ersa's revolutionary and patented Hybrid Rework Technology for safe removal and replacement of small SMDs. Safe, medium wave IR radiation combined with a gentle hot-air stream guarantees optimal energy transfer to the component.

The HYBRID TOOL delivers smooth and homogeneous heat to components sizing from 0201s to 20 x 20 mm SMDs and even larger.

The user-friendly operation allows for even non-experienced operators to handle the HR 100 safely and quickly.

The handle of Ersa's ergonomically designed HYBRID TOOL contains a positioning laser which helps the operator to focus the heat precisely throughout the entire process. Via the USB 2.0 port, the HR 100 can be connected to Ersa's top of the line and well-established IRSoft rework software.

Ordering information:

Order number	Description
01RHR100A	HR 100 hybrid rework system with 200 W HYBRID TOOL, 3 hybrid adapters, adapters changer, VAC-PEN and HYBRID TOOL holder
01RHR100A-HP	HR 100 and IRHP 100 hybrid rework system complete with heating plate incl. stand with HYBRID TOOL holder

Ersa RPC 500

Unbeatable in price and performance!

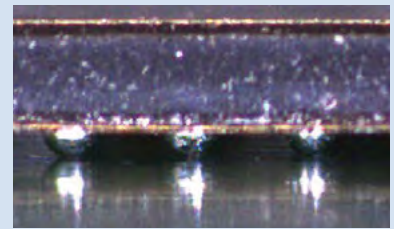

High magnification of Tessera CSP

RPC 500



RPC 500 with IRHR 100 A-HP

The RPC 500 unit offers rework process observation at the lowest cost possible. The 70 x optical magnification MACROZOOM lens delivers highest quality and high magnification images of the finest applications.

Two LED spotlights fixed on top of flexible arms provide for an optimal illumination of the "rework scene".

Mounted on its bottom side, the 180° swivel arm carries the camera and offers maximum flexibility of process viewing angles.

This unit can be used in combination with the IR 550, HR 200, HR 100, IRHP 100 and any other hand tools.

The camera is connected over a USB cable to the PC and the live image is visualized through IRSoft.

Features of the RPC 500

- High-quality CMOS USB 2.0 camera
- 70x optical MACROZOOM lens
- Two LED spotlights with flexible arms and variable intensity
- Free swivel arm (180°), stable stand
- Fits for IR 550, HR 200, HR 100 and IRHP 100



RPC 500 with IR 550

Ordering information:

Order number	Description
0VSRPC500A-LE	Reflow Process Camera, complete



Ersa MACROZOOM

DIP&PRINT STATION

for Erska rework systems

Removal of the component from the print stencil



The Erska DIP&PRINT STATION enables the user of an Erska rework system to easily, reliably and reproducibly perform the preparatory work on the component (application of solder paste or flux).

Optional dip stencils permit – using defined parameters – to immerse the components into flux and in solder paste, building up a defined depot on the contacts to be soldered. This method is suitable for BGAs and for most Fine-Pitch components. For example, using a component-specific stencil, solder paste depots on QFN/MLF connections and those of other SMD components can be added easily and precisely.

To apply solder paste, the component is fixed in the print stencil at first. Then the solder paste is printed from below to the component. Subsequently, the placement unit lifts the component out of the stencil and places it on the target position.

A suitable rack fixation is available for each Erska rework system to mount the stencil frame of the DIP&PRINT STATION on the placement system.



Flux deposition in the dip stencil

Ordering information:

Order number	Description
OPR100	DIP&PRINT STATION
OPR100-PL550	Rack fixation PL 550
OPR100-PL650	Rack fixation PL 650
Customized stencils available on request	

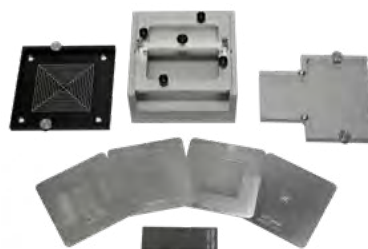

Dip&Print Station with accessories

Features of the DIP&PRINT STATION

- Easy solder paste printing
- Component dip-in for flux and solder paste deposition
- Fits to all Erska rework systems
- Easy to change stencils
- Easy to clean system components

Difficult Applications – No Problem!

Ersa rework systems handle the most complex rework applications

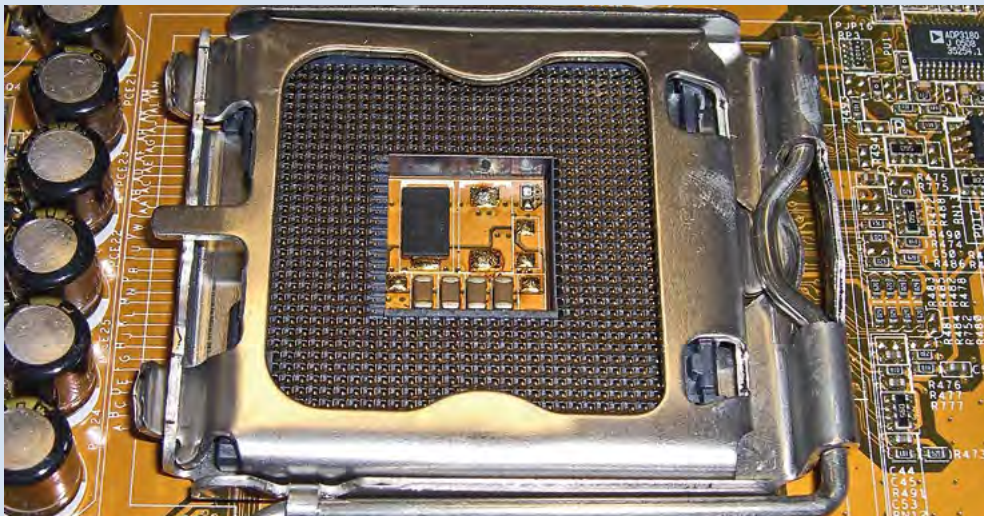

LGA 775 Processor Socket



BGA plastic socket



Ultra heavy-mass PGA

The purchasing decision for today's rework equipment goes to the company that can GET THE JOB DONE!

Rework applications specialists at Ersa have proven the flexibility of our systems by handling applications where other units failed.

Some of the most difficult of these applications include: stacked BGA packages (RAM, DIMM module), top- and bottom-side shadowed BGAs, mobile phone shield and BGA rework, rework on aluminium composite boards, BGA desoldering with heat sink glued on component, LGA775 THT socket exchange, BGA on flex circuit, reworkable epoxies, and large plastic BGA processor sockets, just to name a few. Please look closely at the application picture gallery on these two pages to

fully understand the true versatility of the Ersa rework systems.

Finally, do not hesitate to contact Ersa directly for special rework applications assistance and training material.



The Ersa IR 550 is IPC's recommended BGA reballing system (source IPC 7711)

Ersa Rework

Takes care of all jobs!



CSP, micro BGA



FCBGA



PBGA on aluminium carrier



TO220 on aluminium carrier with hybrid rework system



CGA with heat sink



Plastic SMD connector

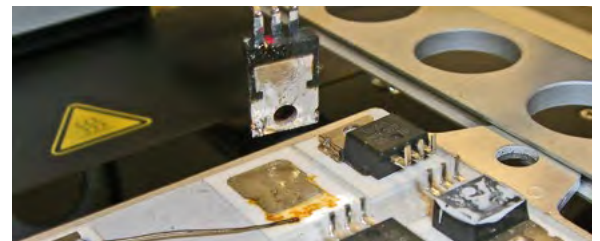

TO220 on aluminium carrier with hybrid rework system



SOIC and plastic SMT on aluminium carrier



Large plastic SMD connector

Heavy-mass aluminium carriers, metal plates and shields, ceramic substrates and even plastic components can be safely reworked with the Ersa Rework Heating Technology!

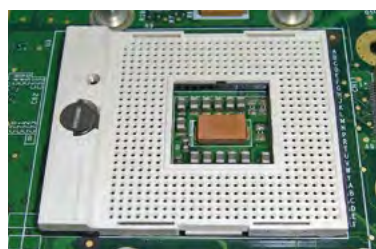

BGA processor socket



BGA GPU

Accessories

Based on our many years of rework experience with many thousands of satisfied customers, we have compiled the most sought-after and useful accessories. Every

accessory table features a "Starter Kit" column, showing the recommended rework starter kit. You will find additional accessories in our soldering tools catalogue.

For inquiries regarding specific soldering tips and special accessories, please contact Erska directly or take a look at: www.ersa.com



Nozzles and suction cups

Order number	Name	Description	Technical data	HR 100	HR 200	IR/PL 550	IR 650	PL 650	HR 550	HR 600/2	HR 600 XL	Starter kit
● 3HR600-06-023	Placement nozzle, 1 mm	Pick & place of smallest components	outer ø 1.0 mm								X	
● 3HR600-06-025	Placement nozzle, 2 mm	Pick & place of small components	outer ø 2.0 mm								X	
● 3HR600-06-022	Placement nozzle, 4 mm	Pick & place of medium-sized components	outer ø 4.0 mm								X	
● 3HR600-06-021	Placement nozzle, 10 mm	Pick & place of large components	outer ø 10 mm								X	
● 0HR5520-05010	Placement nozzle, 1 mm	Pick & place of smallest components	outer ø 1.0 mm						X		X	
● 0HR5520-10020	Placement nozzle, 2 mm	Pick & place of small components	outer ø 2.0 mm						X		X	
● 0HR5520-20033	Placement nozzle, 3.3 mm	Pick & place of medium-sized components	outer ø 3.3 mm, inner ø 2.2 mm						X		X	
● 0HR5520-35050	Placement nozzle, 5 mm	Pick & place of medium-sized components	outer ø 5.0 mm, inner ø 3.5 mm						X		X	
● 0HR5520-80100	Placement nozzle, 10 mm	Pick & place of large components	outer ø 10 mm, inner ø 8.0 mm						X		X	
● OPL6500-13	Nozzle, 0.8 mm	Pick & place of smallest components	outer ø 0.8 mm					X				
● OPL6500-14	Nozzle, 1.2 mm	Pick & place of very small components	outer ø 1.2 mm					X				
● OPL6500-15	Nozzle, 3 mm	Pick & place of small components	outer ø 3.0 mm					X				
● OPL6500-16	Nozzle, 4 mm	Pick & place of medium-sized components	outer ø 4.0 mm					X				
● OPL6500-17	Nozzle, 10 mm	Pick & place of large components	outer ø 10 mm					X				
● OPL6500-18	Nozzle, 10 mm, rubber lined	Pick & place of heavy/smooth components	outer ø 10 mm, rubber lined					X				
● OPL500A-S00.8	Nozzle, 0.8 mm ø	Pick & place of smallest components	outer ø 0.8 mm			X						
● OPL500A-S01.2	Nozzle, 1.2 mm ø	Pick & place of very small components	outer ø 1.2 mm			X						
● OPL500A-S003	Nozzle, 3 mm ø	Pick & place of small components	outer ø 3.0 mm			X						
● OPL500A-S004	Nozzle, 4 mm ø	Pick & place of medium-sized components	outer ø 4.0 mm			X						
● OPL500A-S010	Nozzle, 10 mm ø	Pick & place of large components	outer ø 10 mm			X						
● OPL500A-S010-G	Nozzle 10 mm ø, rubber lined	Pick & place of heavy/smooth components	outer ø 10 mm, rubber lined			X						
● OIR5500-40	MicroPickup, type 0510	Lifting of smallest components, rigid	outer ø 1 mm, inner ø 0.5 mm, brass			X	X			X		
● OIR5500-41	MicroPickup, type 1020	Lifting of very small components, rigid	outer ø 2 mm, inner ø 1 mm, brass			X	X			X		
● OIR5500-44	Suction adapter small	Adapter for small suction cups	for cups of 2 mm and 3.5 mm			X	X			X		
● OIR5500-45	Suction adapter large	Adapter for large suction cups	for cups of 5 mm and 8 mm			X	X			X		
● OIR4520-01	Silicone suction cup, OD 8 mm	Lifting of large components, flexible	outer ø 8 mm, silicone			X	X		X	X	X	3
● OIR4520-02	Silicone suction cup, OD 5 mm	Lifting of medium-sized components, flexible	outer ø 5 mm, silicone			X	X			X		3
● OIR4520-03	Silicone suction cup, OD 2 mm	Lifting of very small components, flexible	outer ø 2 mm, silicone			X	X			X		
● OIR4520-07	Silicone suction cup, OD 1 mm	Lifting of very small components, flexible	outer ø 1 mm, silicone, for OIR0500-40			X	X			X		
● OIR4520-04	Viton® suction cup, OD 8 mm	Lifting of large components, flexible	outer ø 8 mm, Viton®, long-life			X	X		X	X	X	
● OIR4520-05	Viton® suction cup, OD 5 mm	Lifting of medium-sized components, flexible	outer ø 5 mm, Viton®, long-life			X	X			X		
● OIR4520-06	Viton® suction cup, OD 3.5 mm	Lifting of small components, flexible	outer ø 3.5 mm, Viton®, long-life			X	X		X	X	X	
● 0HR5520-20	Suction cup, OD 2 mm	Pick & place of medium-sized components	outer ø 2 mm, silicone, for 0HR5520-20033						X		X	
● 0HR5520-35	Suction cup, OD 3.5 mm	Pick & place of medium-sized components	outer ø 3.5 mm, silicone, for 0HR5520-35050						X		X	

Viton® is a registered trademark of Dupont Dow Elastomes

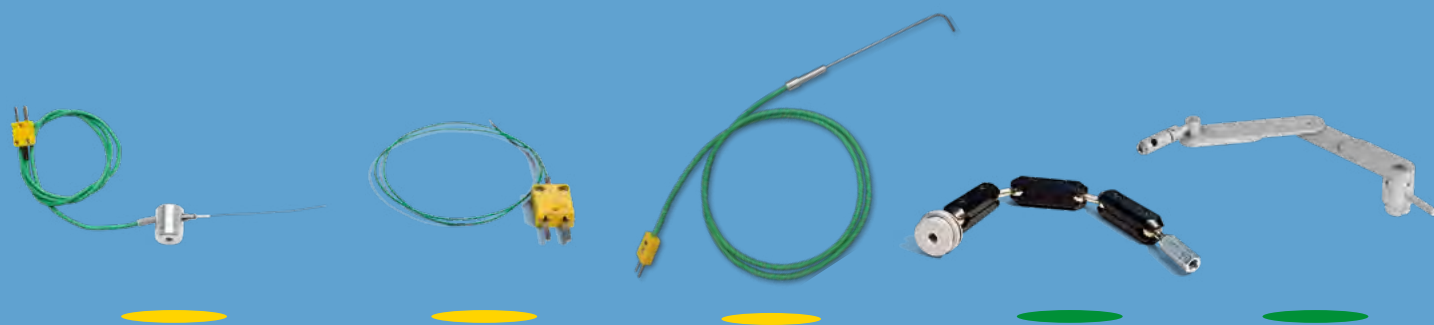

Nozzles and suction cups

Order number	Name	Description	Technical data	HR 100	HR 200	IR/PL 550	IR 650	PL 650	HR 550	HR 600/2	HR 600 XL	Starter kit
0HR5520-80	Suction cup, OD 8 mm	Pick & place of large components	outer Ø 8 mm, silicone, for 0HR5520-08100						X		X	
0SVP07S	Suction cup	for VAC-PEN 0VP020	outer ø 7 mm, silicone	X		X	X					
0SVP13A	Kit of suction cups	for VAC-PEN 0VP020	outer ø 4, 6, 9 mm, NBR	X			X					

Viton® is a registered trademark of Dupont Dow Elastomes

Temperature sensors

Order number	Name	Description	Technical data	HR 100	HR 200*	IR/PL 550	IR 650	PL 650	HR 550	HR 600/2	HR 600 XL	Starter kit
● 0IR6500-01	AccuTC thermocouple	Temperature measurement at component	Sheathed thermocouple, K-type, ø 0.5 mm	X	X	X	X		X	X	X	
0IR6500-37	AccuTC sensor without fixture	Spare element without fixture	Sheathed thermocouple, K-type, ø 0.5 mm	X	X	X	X		X	X	X	
● 0HR645	AccuTC2.0 thermocouple	Temperature measurement at component	Sheathed thermocouple, K-type, ø 1.5 mm	X	X	X	X		X	X	X	
● 0IR4510-02	Thermocouple wire	Temperature measurement	Ni-Cr-Ni wire, thermo-plug	X	X	X	X		X	X	X	
● 0IR5500-35	Flexpoint TC holder	Adjustable holder for AccuTC	Length 210 mm	X	X	X	X		X	X	X	
0IR5500-36	Flexpoint extension	Extension	Length 210 mm	X		X	X		X	X	X	
● 0HR640	TC holder	Adjustable holder for AccuTC	Length approx. 170 mm, height approx. 48 mm	X		X	X		X	X	X	

* in combination with ODTM103



Additional equipment

Order number	Name	Description	Technical data	HR 100	HR 200	IR/PL 550	IR 650	PL 650	HR 550	HR 600/2	HR 600 XL	Starter kit
● 0IR5500-13	Cooling fan	PBC cooling	Air volume: 160 m³/h	X	X	X						
0IR5500-43	Deflector hood	Deflection of the airflow	Aluminium	X	X	X						
● 0PL500A-SPC	Split optic cassette for PL 550	Magnified view of component corners	For components with diagonal of 21 - 50 mm			X						
● 0PL6500-11	Split optic cassette for PL 650	Magnified view of component corners	For components with diagonal of 15 - 55 mm					X				
● 0DTM103	Temperature measuring device	Digital temperature measurement	For K-type thermocouples, battery driven	X	X	X	X		X	X	X	X
● 0IR5500-33	ROBAX® glass plate for IR 550	Glass plate cover for heating elements	ROBAX® glass plate			X						

Accessories

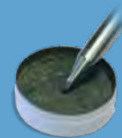
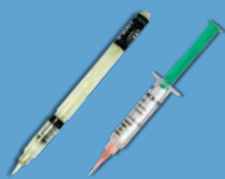

Consumable items

Order number	Name	Description	Technical data	HR 100	HR 200	IR/PL 550	IR/PL 650	HR 550	HR 600/2	HR 600 XL	Starter kit
● 010MM0250LF02	Solder wire	Solder wire, Sn96.5Ag3.0Cu0.5	1 mm diameter, 250 grams	X	X	X	X	X	X	X	1
● 0WICKNC2.2	No-Clean desoldering wick	Removal of solder	Width 2.2 mm, length 1.5 m	X	X	X	X	X	X	X	
● 0WICKNC2.7	No-Clean desoldering wick	Removal of solder	Width 2.7 mm, length 1.5 m	X	X	X	X	X	X	X	1
● 4FMJF8001-PEN	FLUX-PEN, Interflux IF8001	Application of flux	With fiberglass brush, refillable, 7 ml	X	X	X	X	X	X	X	
● 4FMJF6000-PEN	FLUX-PEN, Interflux IF6000	Application of flux, for lead-free applications	With fiberglass brush, refillable, 7 ml	X	X	X	X	X	X	X	1
● 4FMJF8300-005	Flux gel	Flux for e.g. SolderWell process	Dispensing cartridge & needle, 5 ml	X	X	X	X	X	X	X	1
● 4FMJF8300-030	Flux gel	Flux for dip processes	Dispensing cartridge & needle, 30 ml	X	X	X	X	X	X	X	
● 0IR4500-40	Heat shielding tape	Heat protection of adjacent components	Width 25 mm, length 1 m, aluminium	X	X	X	X	X	X	X	1
● 0IR4500-07	Capton tape	Heat-resistant tape	Width 25 mm, length 10 m	X	X	X	X	X	X	X	1
● 0IR6500-46	PTFE glass cloth tape	Heat-resistant tape to improve IRS reading on reflective surfaces	Width 40 mm, length 5 m	X	X	X	X	X	X	X	
● 0TR01/SB	TIP-REACTIVATOR	Reactivation of passive soldering tips	Lead-free, 15 g can	X	X	X	X	X	X	X	1
● 0TR02/SB	TIP-REACTIVATOR	Reactivation of passive soldering tips (new: without abrasives)	Lead-free, 30 g can	X	X	X	X	X	X	X	
● 0FR400	FLUX-REMOVER	Removal of flux and cleaning of PCBs	Spray can with brush, 400 ml	X	X	X	X	X	X	X	1

A complete list of solders and desoldering wicks is available in the Ersa tools catalog or online at www.ersa.com

Soldering tips

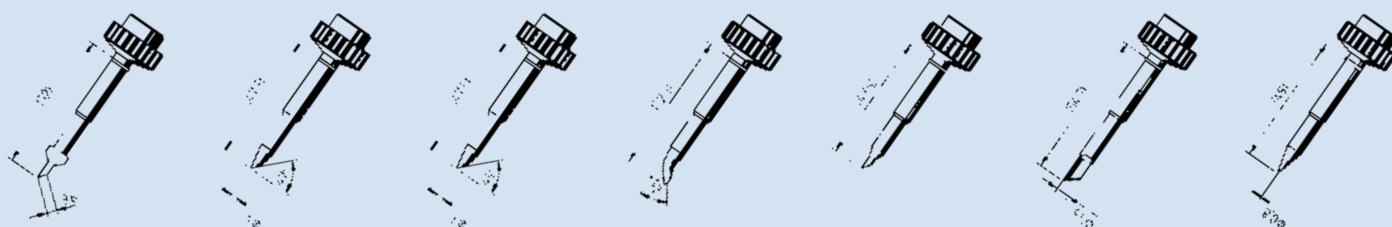

Soldering tips for rework applications are available in our Ersa soldering tools catalog or on our website at: tips.ersa.de

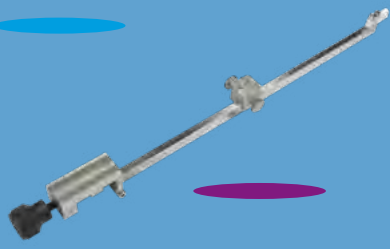
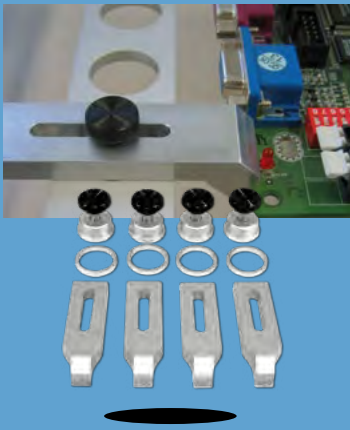

PCB holders and more

Order number	Name	Description	Technical data	HR 100	HR 200	IR 650	PL 650	HR 550	HR 600/2	HR 600 XL	Starter kit
● 0IR5500-01	x/y PCB table	Fixture for PCBs or PCB holders	Recommended PCB size up to 280 x 390 mm	X	X						
● 0PL500A-LP01	Support for PCB holder	Support & fixture to prevent PCB warpage	4 pcs., length 250 mm each, stainless steel	X							
● 0PH360	PCB holder	Fixture and support of medium-size PCBs	Recommended PCB size up to 270 x 365 mm			X	X				
● 0PH100	PCB holder	Fixture of small PCBs	Recommended PCB size up to 170 x 170 mm	X	X	X	X				
● 0IR6500-16	PCB holder	Fixture and support of large PCBs	Recommended PCB size up to 460 x 560 mm			X	X				
● 0IR6500-17	PCB holder set	Fixture of odd shaped PCBs	4 pcs, 30 mm adjustable length per clamp	X	X	X					
● 0HR625	PCB holder for HR 600/2	Support and fixture of PCBs	Recommended PCB size up to 300 x 390 mm						X		
● 0HR635	PCB holder for HR 600 XL	Support and fixture of PCBs	Recommended PCB size up to 625 x 625 mm							X	
● 0HR655	Additional PCB clamp	Support and fixture of odd shaped PCBs	40 mm range per clamp, 1 piece	X	X	X		X	X		
● 0HR554	PCB holder HR 550	Fixture and support of PCBs	Recommended PCB size up to 382 x 300 mm					X			
● 0HR554-01	Support bar with pin	Support of PCBs	Length 274 mm					X			

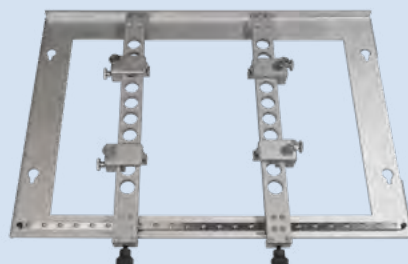
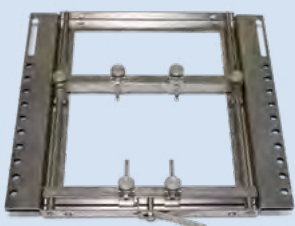
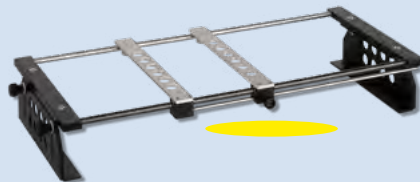
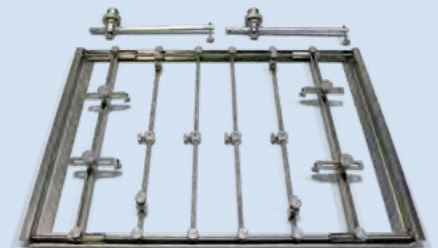
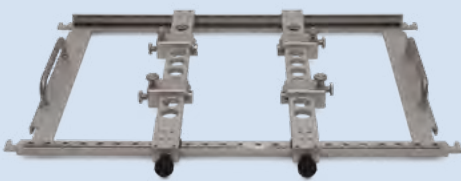

Accessories

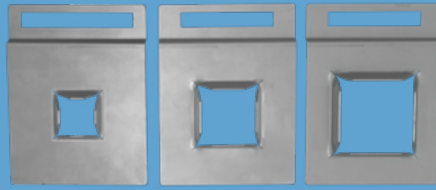
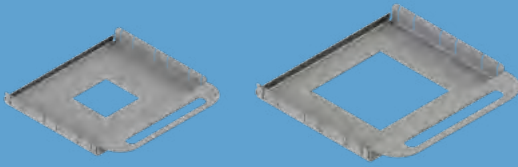

Baffles for HR 550

Order Number	Name
0HR5530-001	Baffle, 30 x 30 mm
0HR5530-002	Baffle, 45 x 45 mm

Baffles for HR 600/2 and HR 600 XL

Order Number	Name
0HR620-001	Baffle, 40 x 40 mm
0HR620-002	Baffle, 30 x 30 mm
0HR620-003	Baffle, 20 x 20 mm

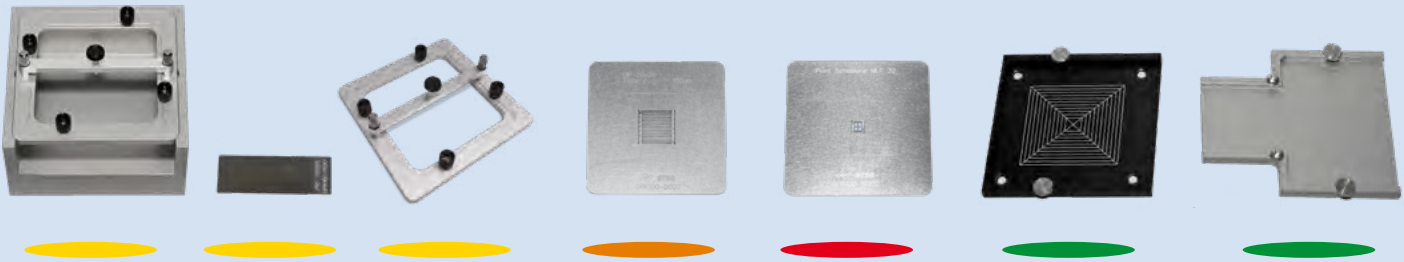

DIP&PRINT STATION

Order Number	Name
0PR100	DIP&PRINT STATION incl. stencil frame and squeegee
0PR100-20	Stencil frame for DIP&PRINT STATION
0PR100-R001	Squeegee, 70 x 25 mm, 0.3 mm thick
0PR100-PL550	Frame fixation for PL 550
0PR100-PL650	Frame fixation for PL 650
0PR100-D001	Dip stencil, 40 x 40 mm / 300 µm
0PR100-D002	Dip stencil, 20 x 20 mm / 150 µm
0PR100-D003	Dip stencil, 20 x 20 mm / 100 µm
0PR100-D004	Dip stencil, 40 x 40 mm / 100 µm
0PR100-S001	Print stencil, type 1, BGA 225
0PR100-S002	Print stencil, type 2, MLF 32
Customer-specific stencils on request	

NOTE:

Ersa's customer service department assists its customers in selecting suitable fluxes and solders pastes for the dip-in and the printing process. For example, Interflux, a manufacturer of fluxes and solder pastes, recommends its product "µ-dlFe7" as dip-in solder paste, and flux gel "IF 8300" for this process.

In order to fabricate a print stencil for a certain product, we would require a datasheet showing the exact dimensions of the body as well as the position of the pins. Depending on the complexity of the stencil, Ersa will issue a suitable proposal.



Information on the DIP&PRINT STATION is available on our website at:
dip-print.ersa.com

Inspection

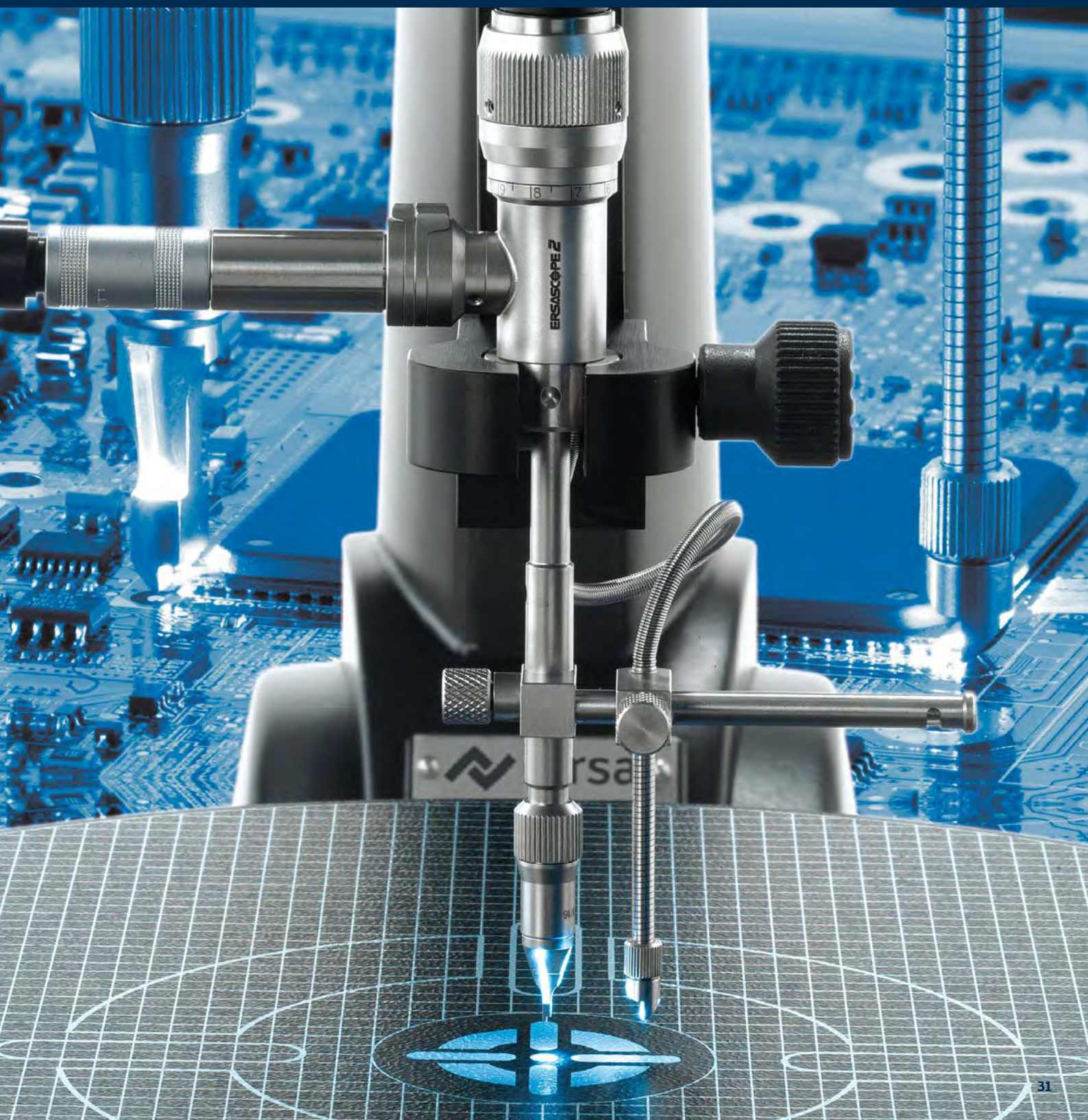

Proper Inspection Can Save Money!

Industry standards like IPC & experts alike promote hidden solder joint inspection

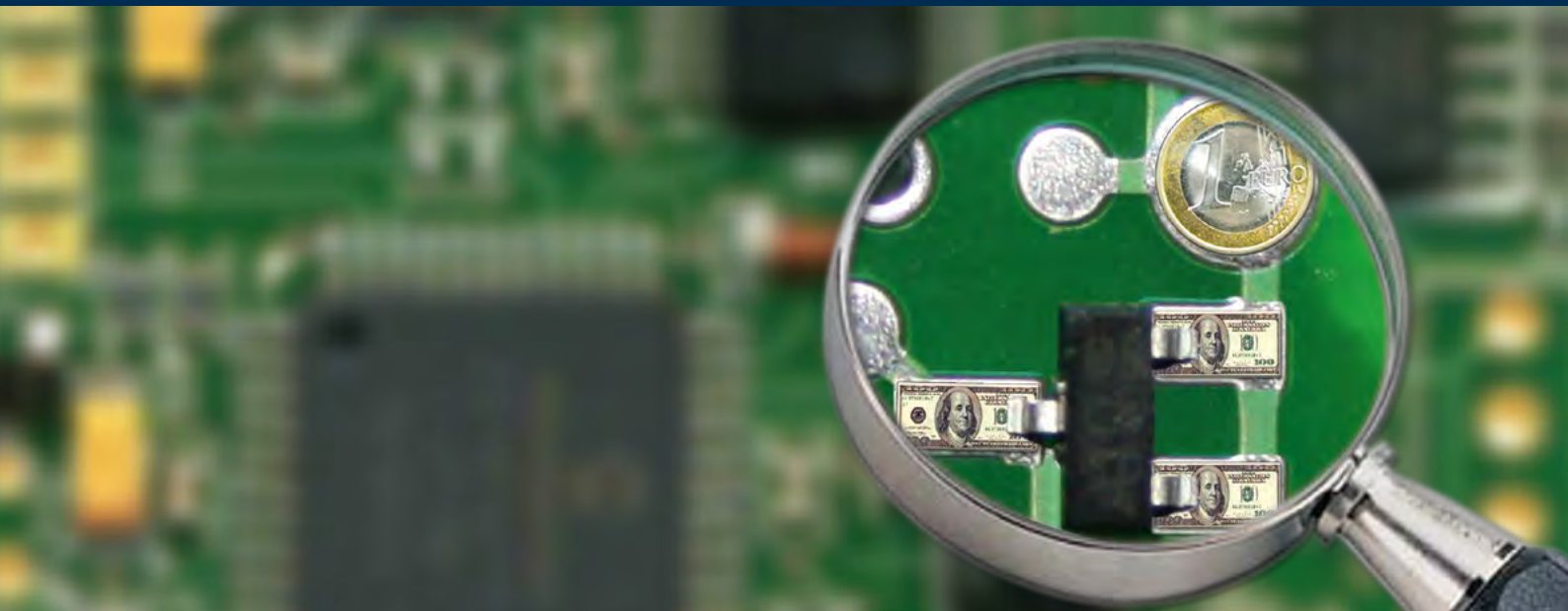

Industry experts rely on endoscopic inspection technology. The IPC standard IPC-7095B (March 2008) recommends the use of endoscopes for BGA inspection.

The introduction of the lead-free processes lead to new problems and required an improved inspection process, as it is offered by the ERSASCOPE technology. The defects

shown in the images below cannot be detected with standard microscopes. If undetected, such problems will result in the improper qualification of the lead-free process.

The award-winning ERSASCOPE is a patented, endoscope-based system specifically designed for hidden solder joint inspection under components like BGAs, CSPs and Flip-Chips.

To See is to Survive – Only by being capable of seeing all potential problems in your process will you be able to react, in order to correct those problems, to assure quality and TO SAVE MONEY!

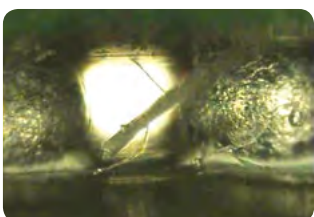

Flux residue under BGA

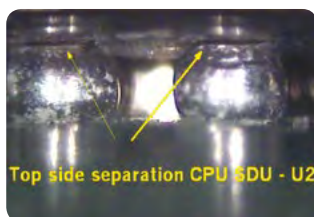

Top side delamination of BGA

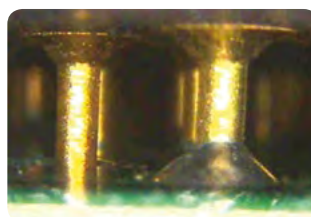

PGA: insufficient hole fill

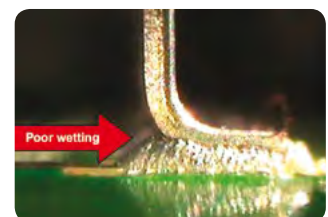

PQFP: missing interior heel fillet

ERSASCOPE

Best in class inspection technology



US patent no. US 6,580501
EU patent no. EP 11 23 525



1999 Dr. Rudolf-Eberle,
Innovation Prize, Germany

1999 Most Innovative Product,
ELENEX Australia

2000 Best Product in Show,
Component & Electronic, Sweden

2000 EP&P Excellence Award,
Nepcon, USA

2000 EP&P Grand Award,
Nepcon, USA

2000 SMT Vision Award,
Best New Product, Inspection, Apex, USA

ERSASCOPE 1 vs. ERSASCOPE 2

Which system is best for which inspection application?



Best in class optical inspection technology for inspecting underneath components

for not only BGA, but also for the hidden, interior joints on SMD and TH components.

The award winning and patented original ERSASCOPE technology has been further developed in order to meet today's lead-free and low component profile challenges.

The ERSASCOPE 2 is currently the ONLY inspection system in the world offering exchangeable optical heads for Flip-Chip, CSP, BGA and Q201 optical inspection.

The ERSASCOPE 1 offers a cost-effective optical inspection solution in accordance with the new IPC Inspection Standards (see IPC -7095B)



*ERSASCOPE 1:
fixed optics
for BGAs*



*ERSASCOPE 2:
exchangeable
optics for CSPs*



*The ERSASCOPE XL
system with retraction
unit and XL-table for
the inspection of over-
sized assemblies.*

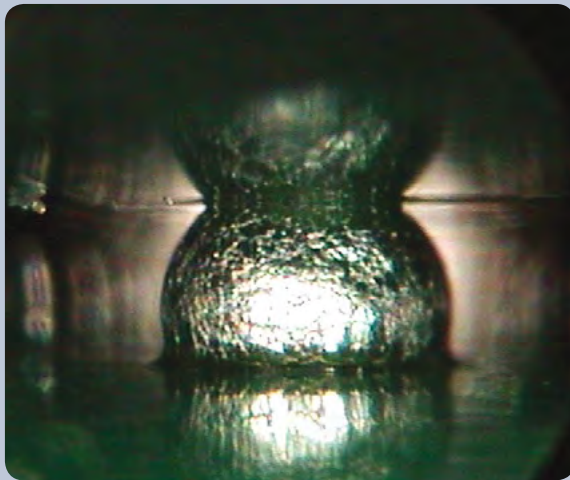

ERSASCOPE 1 image of BGA (gap ~ 300 μm)

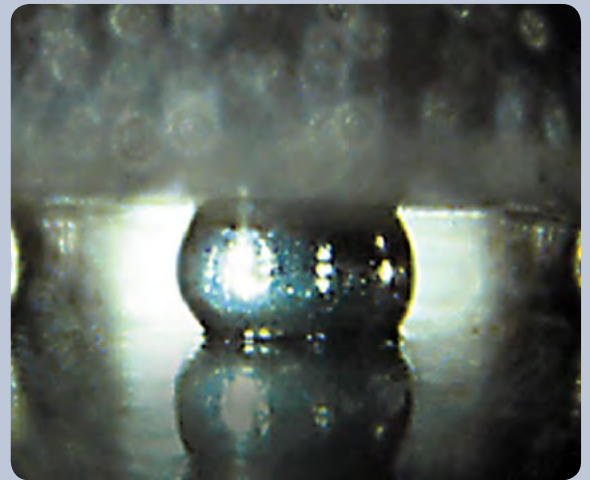

ERSASCOPE 2 image of Flip-Chip (gap ~ 30 μm)

Whereby both ERSASCOPE systems are fundamentally similar in their capabilities, they differ technically in the following functional areas listed in the technical comparison table below.

When considering inspection applications, the two ERSASCOPE systems differ with respect to the standoff height of the component to be

inspected and the density of the PCB. The 90° lens of the ERSASCOPE 1, for example, has a footprint of 1.5 x 4.5 mm, a magnification of up to 400x* and a typical inspection gap of ~ 300 μm. The Flip-Chip optical lens of the ERSASCOPE 2, on the other hand, has a footprint of only 0.6 x 4.0 mm, a magnification of up to 700x* and a typical inspection gap of ~ 30 μm.

Low standoff components such as CSPs and Flip-Chips are thus better inspected with the ERSASCOPE 2 system.

*20" monitor, 1600 x 1200 pixel resolution, no digital zoom

Technical comparison:

Part	ERSASCOPE 1	ERSASCOPE 2
Optical head	Endoscope with fixed integrated lens	Endoscope with exchangeable lenses
Camera	Digital USB camera	High-resolution CCD, 1.3 megapixel
Light source	Halogen	Metal halide
Table	x/y	x/y rotation
Software	ImageDoc	ImageDoc

ERSASCOPE 2

The world's only optical inspection system for Flip-Chips and CSPs



The ERSASCOPE 2 comes standard with an LED light source. The LED light offers a much cleaner and brighter white light compared to other systems. The light quantity is regulated electronically without changing temperature or color of the light during dimming. Two mechanical irises on the optic carrier allow for an individual and separate continuously variable dimming (0 to 100 %) of the front- and backlights. Also standard is a newly designed fiber optic light brush made up of individual fibers (0.050 mm diameter) which can be inserted under most area array packages for optimal illumination during inspection.

Optical carrier

The ERSASCOPE 2 optical carrier is a highly advanced, endoscope-based system offering a rapid exchange of the 3 robust optical heads (lenses) as well as precise image focussing and superior light management. Value added features include:

- ❑ Fiber optic front and backlights with mechanical iris, adjustable from 0 to 100 %
- ❑ Swing-out and fixture mechanism of backlight arm
- ❑ Connection and fastening of the 3 optical heads
- ❑ Focus ring with measurement scale
- ❑ "One Click" interface for fiber optic light cable



Easy to change and robust optical heads offer the greatest inspection flexibility

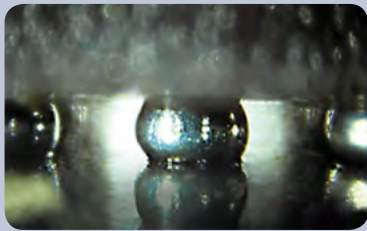
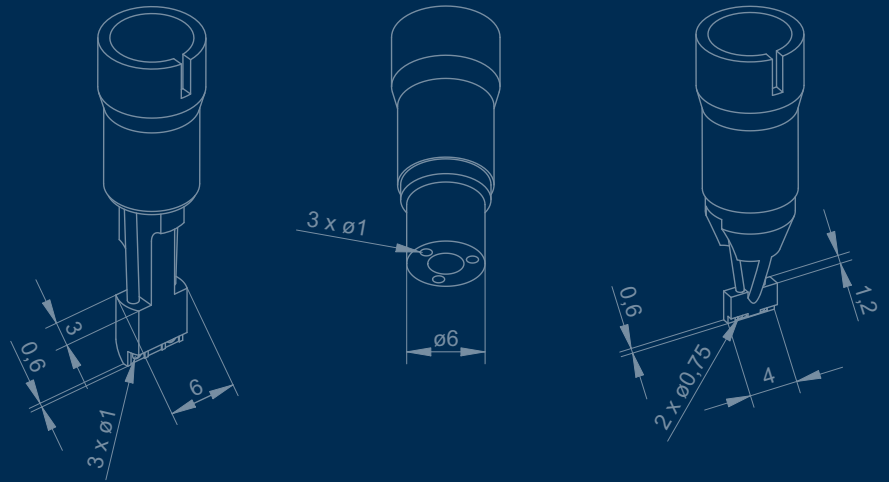

90° Flip-Chip head

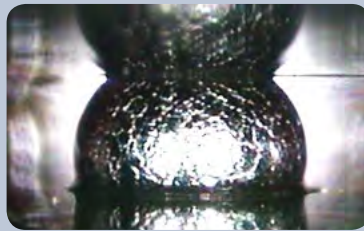

90° SMD & BGA head

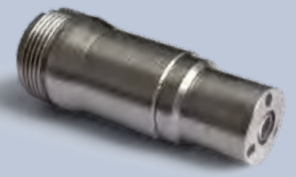
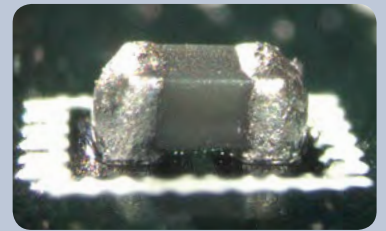

0° microscope head

Flip-Chip 90° optical head

The revolutionary Flip-Chip optical head has the smallest footprint in the industry (0.6 x 4.0 mm) and has been specifically designed for use on densely packed PCBs. The ERSASCOPE 2 Flip-Chip head's aperture height is so low that it is now possible with a magnification of up to 700x to inspect even a typical gap of ~ 30 µm. The critical top-side Flip-Chip joint, never before seen by any BGA optical inspection equipment on the market, is now visible!

Ordering information:

Order number	Description
0VSSC600	ERSASCOPE 2 inspection system, complete
0VSSE200-90K	90° optical head
0VSSE200-FCK	Flip-Chip optical head
0VSSE200-0K	0° optical head

BGA 90° optical head

The ERSASCOPE 2 BGA optical head provides a high-resolution, 90° viewing angle under the component. This light sensitive optical lens offers a 425x magnification in a typical inspection gap of ~ 300 µm and a footprint of 3 x 6 mm. The digital zoom makes it possible to inspect the interior joints underneath the BGA component!

“Look down”, 0° optical head

The wide angle, 0° optical head offers viewing similar to a microscope. The integrated fiber optic lighting perfectly illuminates and magnifies up to 250x for high-contrast surface and via hole inspection.

Features of the ERSASCOPE 2

- High-resolution USB 2.0-CCD camera
- Flip-Chip optical head (700x magnification, gap ~ 30 µm)
- BGA optical head (425x magnification, gap ~ 300 µm)
- Wide angle 0° “look down” optical head (250x)
- Optional high-quality MACROZOOM head (70x) with fiber ring light
- Long-life LED light source
- Light management: fiber optic front and backlights with mechanical iris, fiber optic light brush and -flat light brush, gooseneck
- Stand and table with a total of 7 axes of movement for the optical heads and the board
- ImageDoc Basic or ImageDoc EXP software for both beginners and advanced operators
- Large problem/solution database
- Advanced recording, measurement and reporting functions
- “Plug & Play” setup

Light, Camera and Action!

Best in class inspection productivity with highest quality images

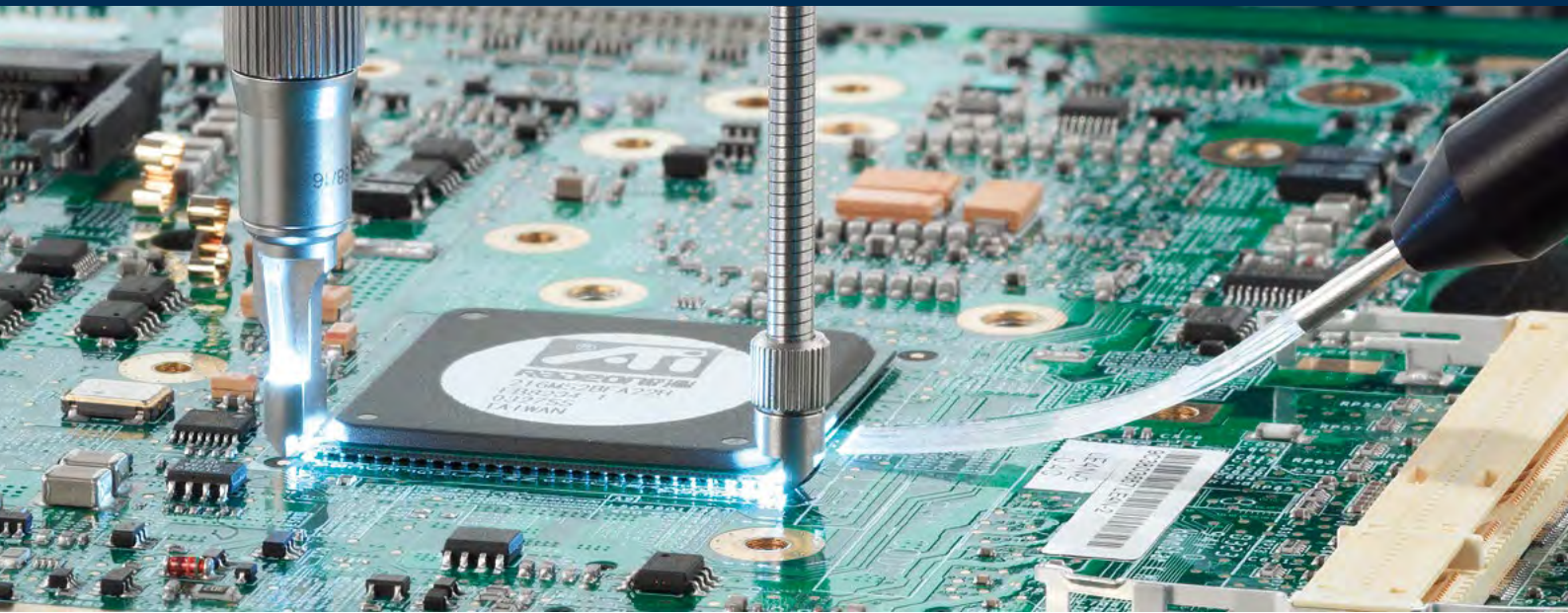

Optimal component illumination is essential for a quality inspection process

Superior light management

The LED light source of the ER-SASCOPE 2 inspection system offers clean and bright white light.

The light quantity is regulated electronically without changing temperature or color of the light during dimming.

Furthermore, all fiber optic light cables have a mechanical iris. Two mechanical irises on the optic carrier allow for an individual and separate continuously variable dimming adjustment from 0 % to 100 % of the front and backlights.

Also standard is a newly designed fiber optic light brush. This new light brush is made up of individual fibers (0.050 mm diameter) which can be inserted under most area array packages and mechanically dimmed for optimal lighting during inspection.



Mechanical irises control both the front & backlights for perfect lighting

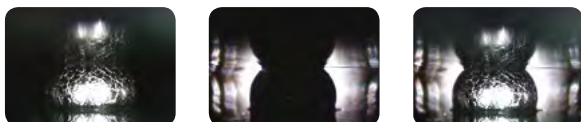

7 axes of movement of the ERSASCOPE optic positioning guarantees maximum flexibility and productivity



High-resolution, light sensitive USB 2.0 camera

In addition to optimal light management, image quality depends not only on precision optics, but also on high-quality camera technology. The high-resolution and highly light sensitive Ersa USB 2.0 camera has 1.3 megapixels and delivers images of highest detail and perfect contrast. Even the smallest object details can be captured, digitally enhanced and used for quality assurance and documentation purposes.

ERSASCOPE inspection stand and table

The ERSASCOPE stand and inspection table offer the most accurate BGA inspection in the fastest cycle time when compared to all competitive systems on the market. The greatest flexibility with a total of 7 axes of movement of the ERSASCOPE optic

positioning is guaranteed: optics pan positions every 90°, unlimited table rotation, unlimited camera rotation, free tilting of optics between +/- 90° with zero degree lock position, x/y/z adjustment in micrometer range.

Removable fibre optic light brush incl. mechanical iris



ERSASCOPE 1

The award-winning and patented original



Optics

The patented ERSASCOPE is the world's first optical inspection system which allows for non-destructive manual inspection of BGAs.

Today over 3,000 users worldwide are benefiting from finding defects that otherwise would have gone undetected by other inspection methods.

The ERSASCOPE 1 optics is a specially designed endoscope with an integrated fiber optic system, focus ring and adjustable backlight; a footprint of 1.5 x 4.5 mm; a magnification of up to 400x and a typical inspection gap of ~ 300 µm.

Camera

The digital camera with USB 2.0 interface uses CMOS technology offering optimal light sensitivity and resolution. The halogen light source supplies optimal light to both the ERSASCOPE 1 optics as well as the flexible gooseneck which is included in the delivery.

Light management

Two light outlets at the optical carrier system and a flexible gooseneck ensure superb light distribution both on the PCB surface and beneath the component.



High magnification and viewing angles from 0 to 90° offer maximum inspection flexibility

Integrated front and back lighting allows for optimal illumination of the hidden joints underneath the component

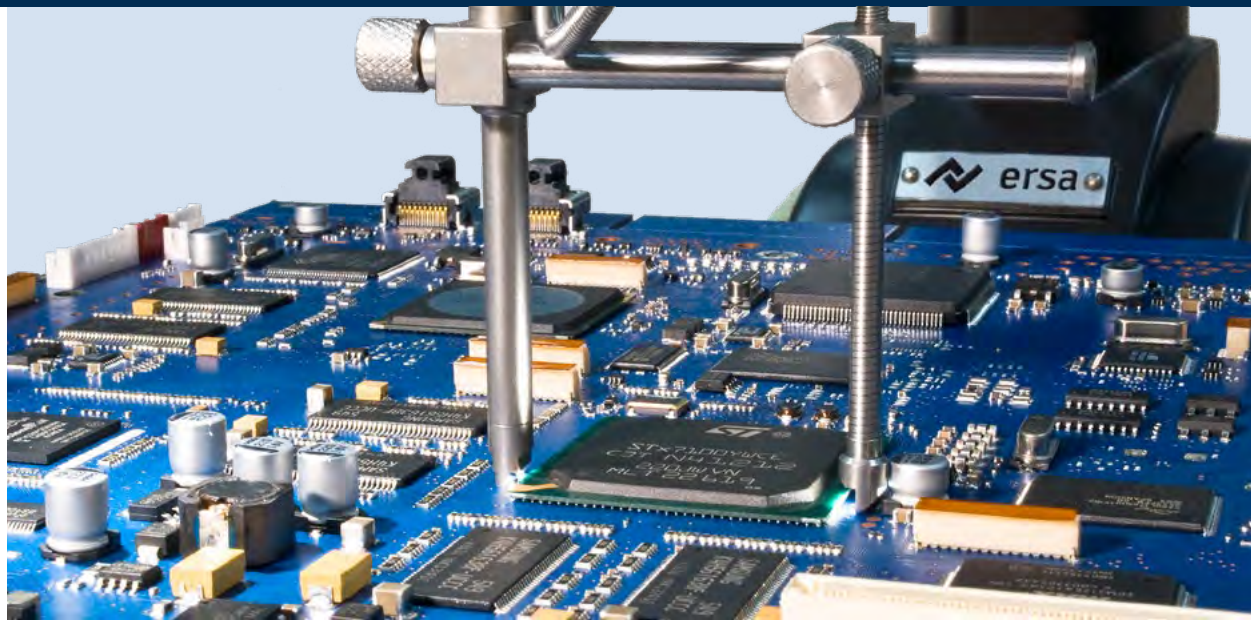

Via mechanical coupling of the back-light with the inspection head, the illumination remains uniform during movement along the component thus allowing for the fastest BGA inspection of any system on the market.

The LED light source of the ERSASCOPE 1 offers a clean and bright white light. The light quantity is regulated electronically without changing temperature or color of the light during dimming.

Table and stands

The multifunctional ERSASCOPE inspection stand includes a z-axis course and fine adjustment of the optics and offers a total of 6 axes of movement for the optics. It is thus possible to view an object at almost any angle! The x/y PCB table has two control wheels for quick and fine positioning of the PCB during inspection.

Software

Image processing and documentation software goes hand in hand with today's inspection requirements. The ERSASCOPE 1 comes standard with ImageDoc Basic inspection software.

Features of the ERSASCOPE 1

- High-resolution USB 2.0 CMOS camera
- High-quality BGA optical head (400x magnification, gap ~ 300 µm)
- High-quality MACROZOOM head (70x) with fiber optic ring light (option)
- High-performance, dimmable LED lighting in daylight colour
- Light management with gooseneck and optional fiber optic light brush or flat light brush
- Stand and table with a total of 6 axes of movement for the optical heads and PCB
- ImageDoc Basic or ImageDocEXP software for both beginners and advanced operators
- Large problem/solution database
- Recording, measurement and reporting functions
- "Plug & Play" setup

Ordering information

Order number	Description
0VSSC070	ERSASCOPE 1 inspection system, complete

Ersa MOBILE SCOPE

Mobile optical inspection system for electronics production



X-Y table



Foot switch for image capture



Stand unit OVSST060



Stand unit for LED light brush



Desktop holder for Ersa MOBILE SCOPE



Stand unit OVSST065 with Ersa MOBILE SCOPE

The Ersa MOBILE SCOPE is a compact and handy, portable video microscope to inspect solder joints in electronic production environments. It has been designed for optical inspection and digital image recording including measurements of solder joints on Ball Grid Array (BGA), μ BGA, CSP and Flip-Chip packages.

Furthermore, the Ersa MOBILE SCOPE can also be used to visually inspect lands, solder paste prints or, in general, to visually inspect components in Surface Mount Technology (SMT) or in Trough-Hole Technology (THT) on the board. The device can be used in quality control, production, laboratories or R&D departments.

The compact Ersa MOBILE SCOPE connects with a PC or any portable computer via a USB interface and is ready for operation within minutes in any location.

By means of the high-quality BGA optical head, components with hidden solder joints can easily be inspected, a MACROZOOM lens allows top-view surface inspection in various magnifications. Both optical heads are plugged onto the high-resolution digital color camera hand piece with a „Quick Snap“ connection. Changing the optical heads in accordance to the inspection task is a matter of seconds.

Inspection
of a CSP



Long-life and very bright, controllable LED lights are integrated in both optical heads and provide optimal illumination of the solder joints. In BGA inspection an additional LED light brush is essential for backlight illumination or to light up very hidden and hard-to-reach areas. Thus soldering errors can be detected quickly and easily with the Erska MOBILE

SCOPE. The Erska MOBILE SCOPE is supplied together with the well-established ImageDoc Basic inspection software. This software not only displays the live images but also provides various possibilities to document and analyze inspection results.

Extensive accessories allow the operator to compose his individual Erska MOBILE SCOPE inspection system according to his needs.

A practical aluminium case offers safe storage of the inspection equipment and facilitates the transportation of the system to any location wherever it is needed.

Features of the Erska MOBILE SCOPE

- High-resolution USB camera
- High-quality BGA optical head (180x)
- Optional 0° optical head (80x)
- Integrated, adjustable LED lighting
- Optional LED fiber optic lighting
- Stand units and further accessories
- ImageDoc Basic or ImageDoc EXP software for both beginners and advanced operators
- Recording, measurement and reporting functions
- Mobile application

Ordering information:

Order number	Description
0VSCA060	Basic camera unit
0VSSC060VK1	Sales kit 1, for details see page 50
0VSSC060VK2	Sales kit 2, for details see page 50
0VSSC060VK3	Sales kit 3, for details see page 50

QFP solder joints –
taken with the Erska
MOBILE SCOPE
MACROZOOM optical
head



Ersa ImageDoc Software

Designed for the inspection personnel containing expert documentation!

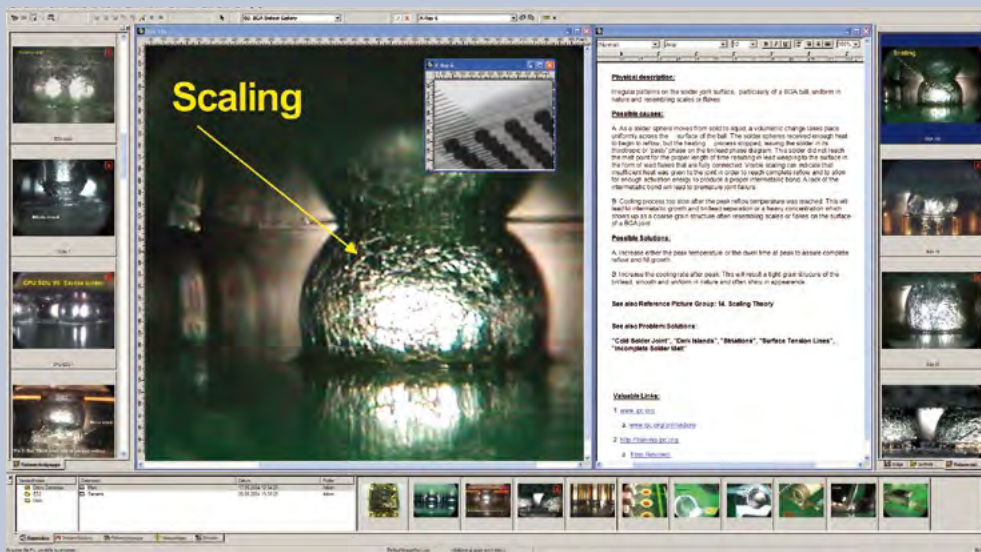

Reference picture databank, live image with "good/bad" reference images



Database & reporting modules to store process & FA info

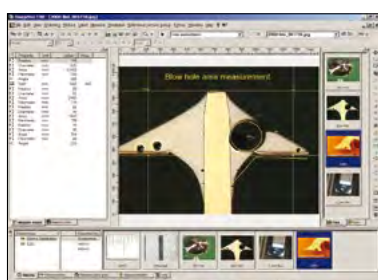

Extensive measurement control and labelling functions

Based on the four fundamental principles of "Inspect, Classify, Analyse and Document", the ImageDoc software platform was designed especially for the inspection personnel. Lead-free implementation required a complete re-training of how operators classify solder joint quality. The days of "If the solder joint looks good, it most likely is good!" are over! By means of software guided inspection processes the personnel can be properly trained for lead-free.

The Ersa ImageDoc software guides the operator through the critical and time consuming process of determining whether a defect exists, and then directs the operator where to look in the process in order to correct the problem. Inspection subjectivity is reduced, problems are solved more quickly and valuable process information is documented for future use.

The included database can be modified and extended by the user at any time. The user can add own reference pictures (with good/bad marking) and problem/solution references.

Features of ImageDoc Basic

- Live and still picture window for documentation and control
- Image database with examples of good and bad solder joints for evaluation purposes
- Reference pictures
- Basic problem/solution database, set up by Ersa, Fraunhofer and the industry
- Measurements and automatic measure control function/calibration
- Image processing and labelling
- Basic reporting/ e-mail out of application
- "Plug & Play" setup

Still sharper views at even more depth ImageDoc EXP with new image processing functions

*"Focus Fusion" –
view of QFP
solder joints*

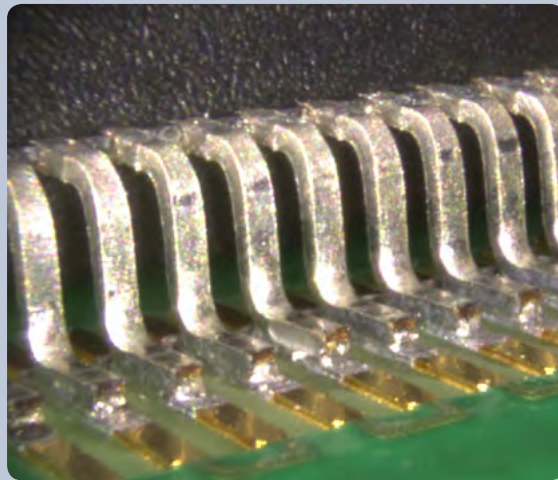

*"Focus Fusion" –
view of a BGA
printed with solder
after it has been
placed*

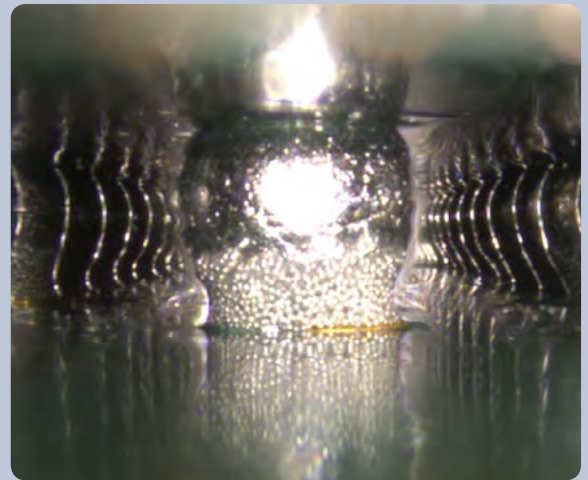

The image process function "Best Focus" enables the ERSASCOPE user to easily find the objectively best sharpness setting for any freely determined portion of the image. This is an especially useful feature when measurements are to be taken within the image.

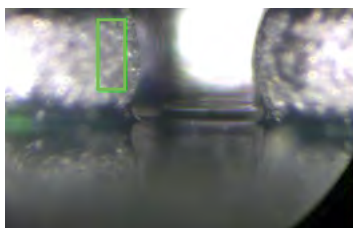

*Best Focus –
blurred picture in
the green framed
section (Area of
Interest) – red bar
graph*

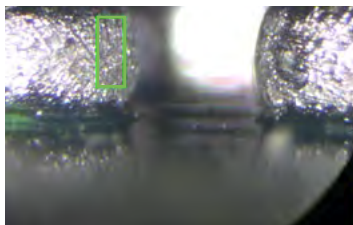

*Best Focus –
focused picture in
the green framed
section (Area of
Interest) – green
bar graph*

The second function serves to improve the presentation and documentation of the inspection results. With "Focus Fusion", the software calculates a composite image with excellent depth of sharpness from a number of previously recorded images. Balls of a BGA, aligned in one row, can thus be viewed with a high clarity and sharpness, for example. Solder defects or irregular solder joints can be inspected far more easily. The inspection result of a component with high pin-out is documented in only one image.

Both functions are available starting with version 3.0 of the well-proven ImageDoc EXP inspection software. An update is available for existing ERSASCOPE customers.

Features of ImageDoc EXP

- Live and still picture, AVI recording, sequence module, presentation mode
- „Best Focus“ and „Focus Fusion“
- Guided failure analysis, supported by an extensive expert database (over 450 MB)
- Reference pictures
- Large problem/solution database, set up by Ersas, Fraunhofer and the industry
- Measurements, automatic measure control function/calibration
- Image processing/labelling, filters and macros
- Network operability, multi-user licensing
- User administration
- Report generation in *.doc and statistics in *.xls/database, import/export, e-mail
- On-line updates and user forum

Inspection applications

Hidden solder joints and further applications

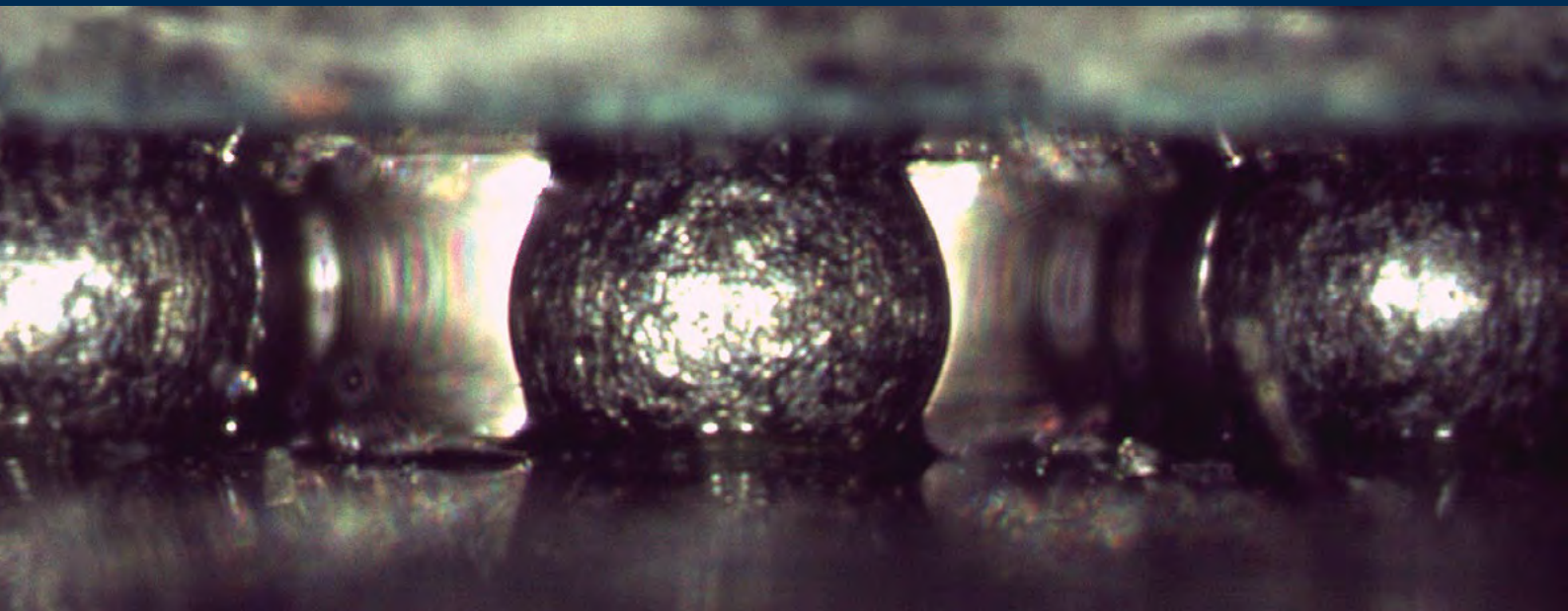

Hidden solder joint inspection is one of the most important areas in a quality assurance program. The images shown on these pages underscore the flexibility of the ERSASCOPE inspection systems.

Whether SMDs or THTs, BGAs or Flip-Chips, the ERSASCOPE offers the perfect complement to existing microscopes and X-ray systems for a total quality assurance program.

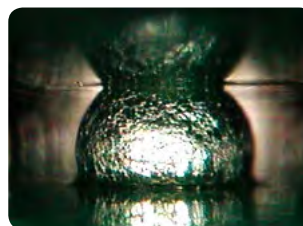

PBGA – scaling: insufficient heat

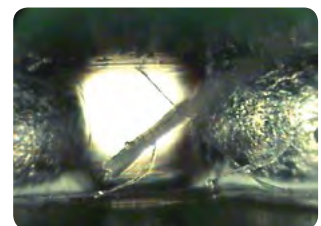

BGA: contamination (fibre)

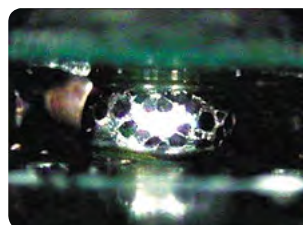

BGA – “dark islands”: overheat

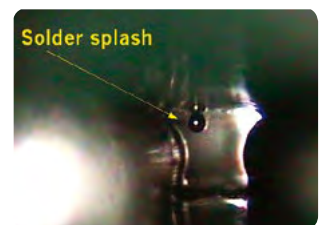

BGA: via hole solder splash

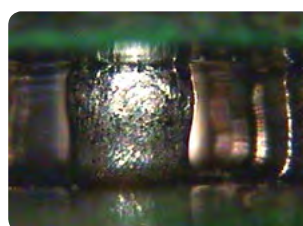

CBGA: good wetting angle

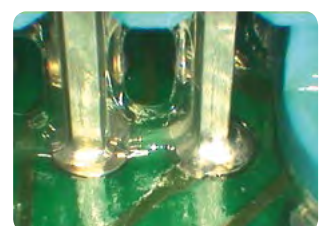

Conformal coating inspection

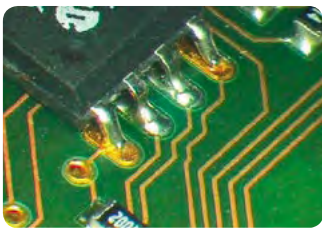

Lead-free assembly: non-wetting

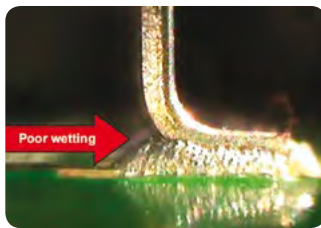

PQFP – interior fillet: poor wetting

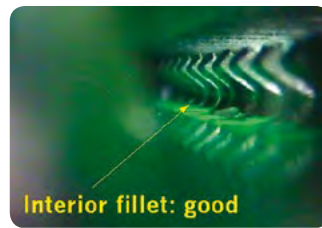

PLCC – interior fillet inspection



PBGA – cold joint: insufficient heat

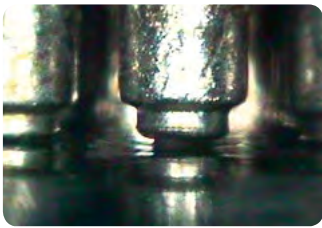

CCGA: insufficient solder



BGA – piggy back: bad alignment

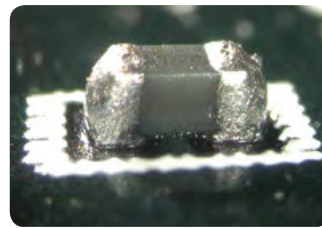

0402: bulbous solder joint

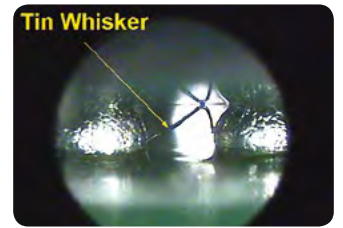

Tin Whisker
PBGA: tin whisker



Lead-free assembly: non-wetting



BGA – paste print: insufficient solder

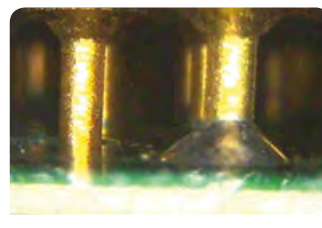

PGA – no flow thru: insufficient heat



PBGA – scaling: insufficient heat

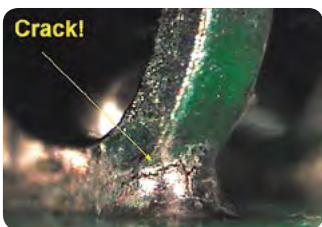

Lead-free PLCC: micro crack

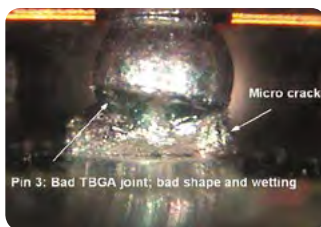

TBGA: disrupted joint & micro crack

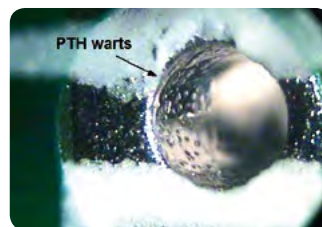

Plated thru-hole: disrupted wall



PBGA – scaling: insufficient heat



SMD LED inspection



PBGA – scaling: insufficient heat

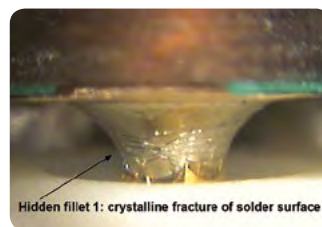

THT joint: crystalline fracture

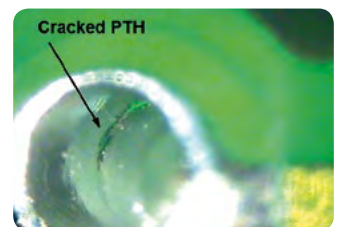

Plated thru-hole: cracked wall

ERSASCOPE 2

System configurations and options







Order number	Description	Technical data	Part
0VSSC600	ERSASCOPE 2 inspection system , consisting of:		
0VSSE200-T	Optical carrier endoscope with integrated lens and fiber optic system	calibration scale, focus ring and two mechanical irises for front and backlight each	
0VSSE200-90K	90° optical head with integrated lens and fiber optic cable	footprint 3 x 6 mm magnification up to 425x* typical inspection gap ~ 300 µm	
0VSSE200-FCK	Flip-Chip optical head with integrated lens and fiber optic cable	footprint 1.5 x 4.5 mm (0.6 x 4.0 mm) magnification up to 700x* typical inspection gap ~ 30 µm	
0VSSE200-0K	0° optical head for surface inspection	footprint ø 6 mm; magnification up to 250x*	
0VSCA2240	High-resolution CCD camera color inspection camera	SXGA, digital (USB 2.0) manual or auto white balance 1.3 million pixels; 1/3" CCD chip	
0VSTV200	TV adapter connects optical carrier to CCD camera	60 mm focal length C-type mount	
0VSL400	LED light source with electronic light quantity regulation and brightness presets	(W x H x D): approx. 170 x 196 x 98 mm 12 VDC, 5,420 mA, max. 65 W weight approx. 2.1 kg	
0VSLR200	● Light regulator for gooseneck	mechanical iris adjusts from 0 to 100 %	
0VSLLV200	● Fiber optic light guide extension	length 200 mm	
0VSLF200	● Light brush	length 35 mm, width 5 mm	
0VSLF300	● Flat light brush	length 80 mm, width approx. 10 to 35 mm	
0VSRM100	● Glass calibration scale	10 µm lines at 100 µm pitch	
0VSLC100	● Lens cleaning kit	cleaning cloth, papers and liquid	
3VP00640	● Storage case	(W x H x D): ~ 325 x 230 x 110 mm aluminium with padded insert	
0VSST210	ERSASCOPE stand with z-axis micrometer adjustment; integrated fiber optic cables and camera cables	(W x H x D): ~ 500 x 400 x 520 mm total weight ~ 5 kg surface: antistatic includes 1,000 mm coated fiber optic cable with gooseneck	
0VSXY100	ERSASCOPE 2 table with 4 PCB supports	X-Y-θ movement with fine adjustment and antistatic mat with grid dimensions: ø 320 mm; weight: ~ 5 kg	
0VSD300L	● ● ImageDoc EXP 3.x	upgrade licence for ImageDoc EXP professional inspection software	
0VSD135	ImageDoc Basic	general inspection software	







● = option for ERSASCOPE 1 ● = option for ERSASCOPE 2

*20" monitor, resolution 1,600 x 1,200 pixels, no digital zoom

ERSASCOPE 1

System configurations and options

Order number	Description	Technical data	Part
0VSSC070	ERSASCOPE 1 inspection system , consisting of:		
0VSSE100	ERSASCOPE 1 endoscope with integrated lens and fiber optic cable	focus ring and adjustable backlight footprint 1.5 x 4.5 mm magnification up to 400x* typical inspection gap ~ 300 µm	
0VSCA1225	Digital color camera with USB port	digital (USB 2.0) manual or auto white balance 1/3" CMOS chip	
0VSTV036	TV adapter connects optical carrier to CCD camera	60 mm focal length C-type mount	
0VSL400	LED light source with electronic light quantity regulation and brightness presets	(W x H x D): approx. 170 x 196 x 98 mm 12 VDC, 5,420 mA, max. 65 W weight approx. 2.1 kg	
0VSST210	ERSASCOPE stand with z-axis micrometer adjustment; integrated fiber optic cables and camera cables	(W x H x D): ~ 500 x 400 x 520 mm total weight ~ 5 kg surface: antistatic includes 1,000 mm coated fiber optic cable with gooseneck	
0VSXY090	ERSASCOPE 1 table with 4 PCB supports	x/y movement with fine adjustment; antistatic mat with grid dimensions: ø 320 mm; weight: ~ 3 kg	
0VSI135	ImageDoc Basic	general inspection software	

Order number	Description	Technical data	Part
0VSUP6XL ● ●	XL Upgrade Kit upgrades the ERSASCOPE stand and table for inspection of very large PCBs	antistatic XL table (600 x 700 mm), telescopic arm, optical carrier system and fiber optic light guide extension	
0VSMS100 ●	MAGNISCOPE head 0° static endoscope with integrated lens and fiber optic cable	focus ring, magnification up to 400x*	
0VSMZ100 ● ●	MACROZOOM head for high-magnification top-view surface inspection	70x zoom lens aperture adjustment: F 5.6 – 32 C focal length: 180 – 450 mm	
0VFR100 ● ●	MACROZOOM ring light	fiber optic ring light	
0VSMZ300H ● 0VSMZ200H ●	MACROZOOM holder	connects optical head to the stand	
0VSSC600VK ●	ERSASCOPE 2 Upgrade Kit upgrade to ERSASCOPE 2	for complete ordering information, please contact your Ersca representative directly	

● = option for ERSASCOPE 1 ● = option for ERSASCOPE 2

*20" monitor, resolution 1,600 x 1,200 pixels, no digital zoom

Ersa MOBILE SCOPE

System configurations and options

Basic camera unit		Description
Image sensor		1/3" N-MOS solid state color image sensor
Number of effective pixels		1,600 (H) x 1,200 (V) pixels (UXGA / 2.0 MP)
Interface		USB 2.0 serial bus
Dimensions		114 (L) x 36 (W) x 51 (H) mm, without cable



0VSCA060

BGA 90° optical head		Description
On-screen magnification		~ 180x – 15x on 14" monitor
Working distance range		~ 0.5 – 30 mm (focusing range)
Field of view		~ 2.0 – 24 mm
Illumination		integrated long-life cool white LED illumination



0VSSE060-90K

MACROZOOM head 80x with LED light		Description
On-screen magnification		~ 80x – 8x on 14" monitor
Working distance range		~ 5 – 200 mm
Field of view		~ 5 – 45 mm
Illumination		integrated long-life cool white LED illumination
Dimensions		43 (L) x 19 (Ø) mm (max. 85 x 35 mm)



0VSSE060-MZ80

LED light brush		Description
Illumination		Cool white LED illumination
Illumination level		64 x 0.250 mm (Ø) plastic optical fibers
Power source		3 x AA (LR06) batteries (alkaline cells recommended)
Dimensions		Ø 26 x 250 mm (max. 40 x 250 mm)



0VSLS030

Ersa MOBILE SCOPE sales kits

Order number	0VSSC060VK1	0VSSC060VK2	0VSSC060VK3
Basic camera unit, digital	1x	1x	1x
BGA lens, 90° optical head	1x	--	1x
MACROZOOM lens 80x with LED light	--	1x	1x
LED light brush with dimmer	1x	--	1x
Desktop holder for camera unit	1x	--	1x
Operating manual	1x	1x	1x
ImageDoc Basic (inspection software)	1x	1x	1x
Aluminium case for Ersa MOBILE SCOPE	--	--	1x

Ersa MOBILE SCOPE accessories

Product name	Order number
Stand unit, height adjustable, with fine adjustment	0VSST060
Stand unit, height adjustable	0VSST065
x/y table	0VSXY060
Stand for LED light brush	0VSLS030H
Foot switch for image capture, with USB port	0VSCA060FS
Ersa lens cleaning kit	0VSLC100
Aluminium case for Ersa MOBILE SCOPE	3VP00703

Ersa – We Can Help You Even More!

Benefit also from our soldering irons, soldering systems, stencil printers and training offers

Innovative and efficient tools and machines to raise the productivity of your electronics production

Ersa, Europe's largest manufacturer of soldering systems, has the largest product range for the joining technology as applied in electronics production.

Hand- and rework soldering tools

An example from the Ersa hand soldering tools product range is the i-CON VARIO multi-channel soldering- and desoldering station, which satisfies the highest demands on soldering and desoldering. On the flagship of the i-CON family, users can connect up to four soldering tools for demanding soldering tasks, for example: the ergonomic i-TOOL AIR S hot-air iron for flexible soldering and desoldering with non-contact energy transfer; the i-TOOL for efficient soldering; the i-TOOL HP for demanding high-mass applications; the CHIP TOOL VARIO for precise desoldering of most delicate SMDs and the X-TOOL VARIO for desoldering through-hole components.

More information about these as well as other members of the comprehensive line of Ersa soldering tools is available in the Ersa tools catalog and online at www.ersa.com.

Printers and soldering systems

In the field of soldering systems we manufacture stencil printers, reflow ovens as well as wave- and selective soldering systems. Due to our longstanding cooperation with many manufacturers of electronic products all over the world, our knowledge of what is required by



Extremely handy, precise and powerful – the CHIP TOOL VARIO desoldering tweezers

the industry has always kept pace with new developments and new processes. Reliability, low defect rates, continuous productivity improvements while keeping the consumption of resources at a very low level as well as low maintenance costs are challenges, which are faced and mastered by Ersa on a daily basis. Learn more from our product catalogs and on our website.

Employee training and services

Ersa offers a comprehensive service program on all levels. While employee qualification takes on more and more importance. Benefit from qualified staff and take advantage of Ersa's training and continuous education programs. You will find more information and current dates in our program flyers or on our website.



Ersa selective soldering technology is globally leading



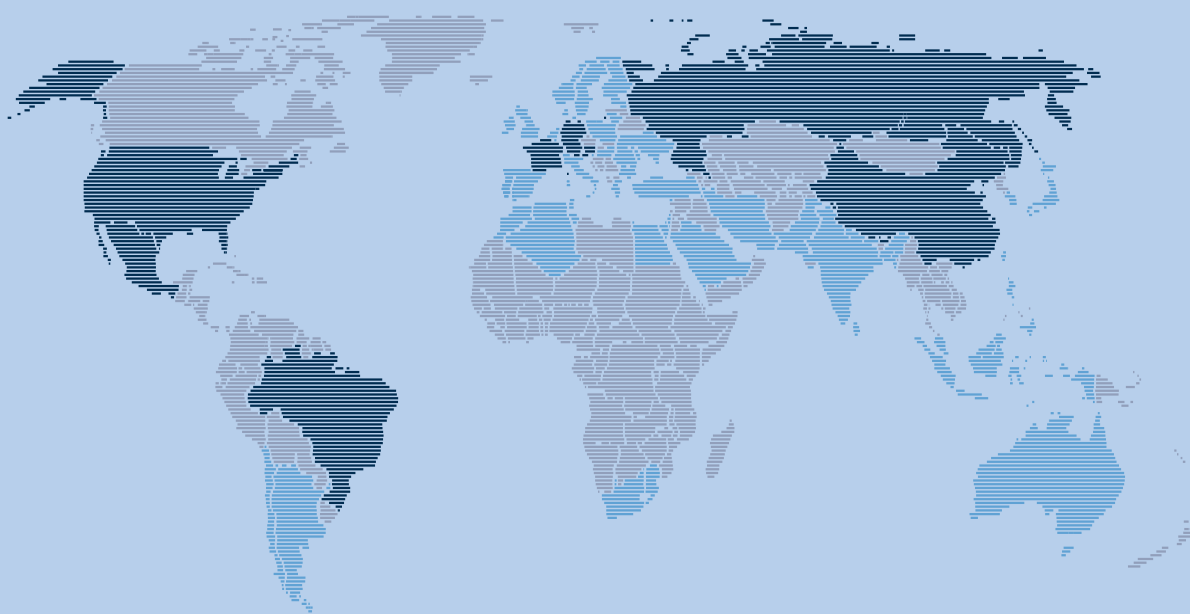

- eigene Vertriebs-/
Serviceniederlassungen
- Vertretungen vor Ort
-



Dystrybutor:

Elblinger Elektronik Sp. z o.o.
ul. Kwiatowa 25
60-185 Skórzewo k. Poznań

Telefon: 061 / 894 69 90
Fax: 061 / 894 69 99

E-mail: mail@elblinger-elektronik.pl
Internet: www.elblinger-elektronik.pl